



Documentation of heat pump retrofits in multi-unit residential buildings

Michaela Neuberger

Greenest City Scholar, 2017

Mentor: Micah Lang

Sustainability Group, City of Vancouver

This report was produced as part of the Greenest City Scholars (GCS) Program, a partnership between the City of Vancouver and The University of British Columbia, in support of the Greenest City Action Plan.

This GCS project was conducted under the mentorship of City staff. The opinions and recommendations in this report, and any errors, are those of the author, and do not necessarily reflect the views of the City of Vancouver or The University of British Columbia.

The following are the official partners and sponsors of the Greenest City Scholars Program:



a place of mind
THE UNIVERSITY OF BRITISH COLUMBIA
sustainability

1. Executive Summary

Context

Vancouver has the goal to derive 100% of its energy from renewable sources by 2050. In order to achieve this, buildings' energy consumption, constituting the largest single source of emissions, needs to be decarbonized.

Multi-unit residential buildings (MURBs) operate 24 hours a day and consume large amounts of energy all year round. In addition, many MURBs in the Lower Mainland are aging and require envelope and mechanical system upgrades. Unique challenges face the rental and condominium residential building stock due to business case, financing, and ownership structure complexities.

Electrically driven heat pumps (HPs) provide a major way to save energy, reduce greenhouse gas (GHG) emissions, and improve comfort. In recent years there have been improvements in HP technologies that can make them viable alternatives to gas fired equipment in the most energy intense areas of MURBs: space heating, domestic hot water, and ventilation. These technologies and applications form the focus of this project.

Project Objectives & Principles

The objective of this project is to facilitate energy retrofits of MURBs by documenting case studies of heat pump (HP) retrofit examples in the Lower Mainland. The case studies are meant to instruct building owners and encourage technology uptake as well as inform updates to the City of Vancouver's Energy Retrofit Strategy for Existing Buildings.

A wide range of stakeholders were contacted to identify MURBs in the Lower Mainland that have installed HP technologies. This included equipment manufacturers, engineering consultants, Strata councils, property management companies, and public sector housing organizations. Participation in the project was voluntary and anonymous. Building names and retrofit project details are only disclosed with the participants' expressed consent.

Case Study Results

Six full length case studies have been documented; four building scale technologies and two in-suite solutions. Half of the case studies are BC Housing sites. Thanks to B.C.'s carbon neutral government mandate, the public sector organization is at the forefront of HP retrofits which is good for industry capacity building and learning across the province.

The case studies contain descriptions of the buildings and equipment installed, document the performance of the systems, and provide a high-level business case of the installation. They also include site pictures, summaries of interviews with Strata councils, unit owners, maintenance managers and consultants on the rationale for the technology retrofits and their user experience.

Overall, the retrofit application of HP technologies in MURBs in the Lower Mainland is still limited. While there is considerable interest in and need for energy efficient retrofits, several barriers have so far prevented the large-scale adoption of electrically driven mechanical equipment in existing buildings.

General Findings

Retrofit Motivations

- Comfort, indoor air quality, maintaining the building condition and raising the property's real estate value are the most important reasons why building owners implement building upgrades.

- Many mid to high-rise MURBs suffer from insufficient ventilation that can lead to poor indoor air quality and moisture issues.
- Many MURBs, in particular buildings with high glass ratios, desire improved heating and cooling.
- Different types of building owners have different concerns, retrofit motivations, and mandates. They should be targeted individually when promoting building upgrades.

Barriers to Retrofits

- Insufficient spare electrical capacity in many existing buildings is a barrier to the adoption of HPs and other electrically driven technologies. Electrical upgrades may be required to bring more power from the utility to the building.
- HP retrofit business cases for MURBs are frequently unattractive. This is due to higher installation costs of these relatively immature technologies on the North American market compared to conventional gas fired equipment. Moreover, low gas prices and comparably higher electricity prices mean that energy cost savings from fuel switching technologies are often not significant. An exception to this are hybrid make-up air units (MAUs) that promise reasonable paybacks of less than ten years with good carbon savings.
- Private building owners and managers frequently decline retrofits due to time constraints, insufficient technical knowledge, and little retrofit project management experience.

Decentralized, In-suite Solutions

- The technology of in-suite solutions such as ductless through-wall heat recovery ventilators (HRVs), and combined heat pumps and air conditioners has improved. These appliances are gaining popularity in retrofit applications.
- In-suite HRVs can enable energy savings. While not being energy savings devices on their own, when combined with envelope upgrades they can provide the required fresh air in a manner that avoids heat loss associated with opening windows.
- In-suite ventilation can overcome the poor performance of corridor pressurization based ventilation systems that are common in mid to high-rise MURBs.

Recommendations

- Accelerate market uptake of energy efficiency measures and fuel switching technologies through incentives, price signals, and regulation. Such incentives can improve the business case and facilitate technology adoption but they must be carefully crafted for different building owner groups.
- Carry out further study into the most appropriate incentive types, regulation and facilitate energy assessments to identify buildings whose mechanical equipment soon needs to be renewed.
- Collaborate with BC Hydro to request that they incentivise HP retrofits by investing into necessary electrical building upgrades.
- Identify pilot projects to implement and test the performance of hybrid MAUs.
- Advertise the non-energy benefits of HP retrofit technologies that speak to building owners' retrofit motivations.
- Develop turnkey programs to assist building owners in managing the retrofit process.

2. Acknowledgements

The renewed opportunity to work for the City of Vancouver as a Greenest City Scholar has been extremely rewarding, both on a professional and personal level. Working for an organization that strives for excellence and demonstrates leadership in the global climate change challenge fills me with meaning and appreciation. I am also grateful for having been part of a dynamic and inspiring team, of whom many members led me through this internship period.

Many people have contributed in a variety of ways in the preparation of this report and the case studies. First, I would like to express gratitude and appreciation to my project mentor, Micah Lang. His guidance and advice played a vital role in the execution of the project.

The findings of this report would not have been possible without the information provided and the insights shared by many individuals. In particular, I would like to thank the building owners and managers, Strata council members, and building and engineering consultants who participated in the case studies, interviews, and site visits. In addition, BC Housing has been very supportive in sharing their data and experiences of the social housing capital renewal projects they managed. All of these stakeholders provided valuable feedback and information that will hopefully encourage the uptake of energy efficient building technologies in the Lower Mainland. Finally, it has been a pleasure to collaborate with Colin Mingus and Lucas Ozols-Mongeau, two Greenest City Scholars who also worked on heat pump related projects in the Green Building team this summer.

3. Table of Contents

- 1. EXECUTIVE SUMMARY3
- 2. ACKNOWLEDGEMENTS5
- 3. TABLE OF CONTENTS6
- 4. GLOSSARY7
- 5. CONTEXT9
 - 5.1. CITY OF VANCOUVER GREENEST CITY ACTION PLAN & RENEWABLE CITY STRATEGY9
 - 5.2. MULTI-UNIT RESIDENTIAL BUILDINGS IN VANCOUVER9
- 6. PROJECT OBJECTIVES 10
- 7. PROJECT METHODOLOGY 10
- 8. CASE STUDY PRINCIPLES, CONTENT & DISSEMINATION 11
 - 8.1. PRINCIPLES11
 - 8.2. CONTENT12
 - 8.3. DISSEMINATION12
- 9. GENERAL FINDINGS 13
 - 9.1. PROJECT RESULTS13
 - 9.2. RETROFIT MOTIVATIONS13
 - 9.3. BARRIERS TO RETROFITS14
 - 9.4. DECENTRALIZED, IN-SUITE SOLUTIONS15
 - 9.5. BC HOUSING16
- 10. RECOMMENDATIONS 17
- 11. CASE STUDIES 18
 - CASE STUDY 1: GREENBROOK, BC HOUSING, SURREY18
 - CASE STUDY 2: CULLODEN COURT, BC HOUSING, VANCOUVER24
 - CASE STUDY 3: CHIMO TERRACE, BC HOUSING, VANCOUVER30
 - CASE STUDY 4: THE DISCOVERY BUILDING, VANCOUVER37
 - CASE STUDY 5: THE MERIDIAN COVE, VANCOUVER44
 - CASE STUDY 6: CONCORDE PLACE, BURNABY51
- 12. CONCLUSIONS 57
- 13. REFERENCES 59

4. Glossary

Air source heat pump (ASHP): A device that absorbs natural warmth from the air outside and distributes it throughout the building. It provides heating in the winter and cooling and dehumidifying in the summer. It is the most common type of heat pump.

The City: Spelled with an upper case C throughout this report; all City departments and staff working for the City of Vancouver (shortened to City staff) under the direction of the City Manager who are responsible for carrying out City operations.

City-wide: Spelled with a lower case c throughout this report; Vancouver wide.

Coefficient of Performance (COP): The COP is the energy output of the heat pump divided by the amount of electricity needed to run the unit. The higher the COP, the more efficient the heat pump.

CO₂e: Carbon dioxide equivalent: CO₂ is the most prevalent greenhouse gas after water vapour and has therefore become the proxy by which we measure greenhouse gas emissions. However, carbon dioxide is only one of many greenhouse gases that are emitted. Other greenhouse gases are methane, nitrous oxide and ozone – all of which occur naturally in our atmosphere. To take into account the emission of other greenhouse gases when calculating the level of greenhouse gas emissions, scientists have devised an equivalent measure – CO₂e – allowing other greenhouse gas emissions to be expressed in terms of CO₂ based on their relative global warming potential (GWP).

CO₂ refrigerant: CO₂ is used as a natural refrigerant in new types of heat pump systems because it has a very low global warming potential (GWP) and does not deplete the ozone layer.

Ductless mini-split heat pumps (mini splits): Devices that are wall-mounted, free-air delivery units that can be installed in individual rooms of a house. They make good retrofit add-ons to buildings with "non-ducted" heating systems, such as hydronic (hot water heat), radiant panels, and space heaters (wood, kerosene, propane).

(Energy) performance contracting: Energy performance contracting is an innovative funding model that is typically applied to retrofitting existing buildings. An energy performance contract makes energy efficiency improvements achievable even if the building owners don't have access to sufficient capital. In such a situation, an ESCO agrees to provide the owner with a set of energy efficient technologies and equipment, and usually arranges the financing to pay for the upgrades so that the owner has to provide little or no capital. Instead, the ESCO takes on the upfront cost and associated risk, and the money saved on energy bills as a result is used to pay the company back until the cost is covered.

Energy services company (ESCO): A commercial or non-profit business providing a broad range of energy solutions including design and implementation of energy savings projects, retrofitting, energy conservation, energy supply, and risk management.

Global warming potential (GWP): A measure of how much a given mass of greenhouse gas is estimated to contribute to global warming because of its ability to trap heat in the atmosphere. GWP is a relative scale which compares the gas in question to that of the same mass of carbon dioxide (whose GWP is equal to 1).

Heat pump (HP): A device that transfers heat energy from a heat source (air, ground, water) to a destination called a "heat sink" (a building). Heat pumps are designed to move thermal energy in the opposite direction of spontaneous heat transfer by absorbing heat from a cold space and releasing it to a warmer one. They can draw heat from air external to a building ('air source') or from geothermal energy ('ground source').

Heat recovery ventilator (HRV): A device that uses the heat in the outgoing stale air to warm up the fresh incoming air. A typical unit features two fans—one to take out building air and the other to bring in fresh air. Its central heat-exchange core transfers heat from the outgoing stream to the incoming stream.

Packaged Terminal Air Conditioners (PTAC): A factory built packaged terminal air conditioner that consists of a wall sleeve and a separate unencased cooling and/or heating component and is intended to cool and/or heat a single room or zone.

Refrigerant: A fluid that circulates through the heat pump in a cycle of evaporation and condensation and thereby absorbs and releases heat energy.

5. Context

5.1. City of Vancouver Greenest City Action Plan & Renewable City Strategy

This project supports the City of Vancouver Greenest City Action Plan (GCAP) and Renewable City Strategy which outline the pathway for Vancouver to reduce its dependence on fossil fuels and take action on climate change.

In 2015, the City Council adopted two main targets:

- Target 1: Derive 100% of the energy used in Vancouver from renewable sources before 2050.
- Target 2: Reduce greenhouse gas (GHG) emissions by at least 80% below 2007 levels before 2050.

When combined, residential, commercial, and industrial buildings are the largest single source of GHG emissions in Vancouver, constituting about 50% of city emissions in 2015 (COV, 2017). Accordingly, the City is tackling building energy use where it has the largest carbon reduction impact – primarily in space heating and hot water.

5.2. Multi-unit residential buildings in Vancouver

To achieve the GCAP Green Building targets, in June 2014 City Council approved an Energy Retrofit Strategy for Existing Buildings that includes a specific focus on multi-unit residential buildings (MURBs). MURBs are responsible for 18% of all building related emissions in Vancouver. In contrast to commercial buildings, MURBs operate 24 hours a day, seven days a week, 365 days per year. As a result, this building demographic consumes large amounts of energy over the entire course of the year. It was therefore decided to focus on this building sector amongst others, to achieve the greatest GHG reduction impact.

Many MURBs in Vancouver and the Lower Mainland are aging and require envelope and mechanical system upgrades to improve the buildings' energy efficiency as well as making them more comfortable and healthy spaces to live in. Unique challenges face the rental and condominium residential building stock due to business case, financing, and ownership structure complexities.

The City is seeking to understand the building-scale technology options and associated economics of retrofitting buildings. Electrically driven heat pumps (HPs) are a major way to save energy, reduce GHGs, and improve comfort. In recent years there have been significant advances in HP technologies for multiple applications relevant to MURBs, such as space heating, domestic hot water (DHW) production, and ventilation. These areas are also the most energy intense in MURBs and often use natural gas as a fuel source. In B.C., natural gas has a carbon intensity 16.8 times that of clean hydro power. Space heating, DHW, and ventilation make up the majority of MURB GHG emissions and are therefore the focus of this project.

6. Project Objectives

The objective of this project is to facilitate energy retrofits of MURBs by documenting case studies of HP retrofit examples that are targeted at building owners and will also be useful to City staff.

Owners of rental buildings and condominiums are often unaware or uncomfortable with the new HP and ventilation technologies. By providing an honest account and feedback from early adopters of these technologies, as well as business case information, the case studies are meant to inform decision-makers and encourage technology uptake.

The unique advantage these case studies offer is peer learning and feedback. By sharing knowledge and experience between landlords and Strata councils, other owners of purpose-built rental buildings and condominiums in the Lower Mainland are more likely to listen and be convinced of the benefits retrofits and heat pump technologies offer. By sharing their perspectives, early adopters are in an exceptional position to provide advice that equipment manufacturers, consultants, and government officials cannot give.

City staff can use the equipment performance data and project business case examples to inform updates to the Vancouver Building Bylaw and the Energy Retrofit Strategy for Existing Buildings. The case studies may also lend support to educational programs and new financial incentives for retrofits.

7. Project Methodology

A systematic approach was used to identify buildings and document the retrofit projects:

1. To find MURBs in the Lower Mainland that have installed HP and ventilation technologies as retrofits, more than 50 different stakeholders were contacted. This included equipment manufacturers, building engineers and mechanical consultants, property management companies, BC Hydro, BC Housing, the BC Non-profit Housing Association (BCNPHA), Strata councils and private landlords.
2. Once buildings were identified, Strata councils, landlords, and consulting companies were contacted to explain the purpose of the project and request their participation.
3. With participants' permission, interviews and site visits were arranged with building managers, maintenance supervisors, and Strata councils to learn about the rationale and steps involved in the retrofit project, the performance of the systems, and the user experience. Equipment manufacturers and consultants, who had worked on the retrofits, were also asked to contribute their expertise of the technologies and projects.

All stakeholders were invited to share their feedback and the lessons learned from the projects, including any recommendations for building owners and managers who may be considering a HP retrofit. During the site visits, pictures were taken of the buildings and the equipment.

4. Stakeholders were asked to share the high-level business case of the installation (pre and post-implementation, if applicable), including information on:
 - Capital and installation costs
 - Maintenance/operating costs
 - Energy savings and energy cost reductions
 - GHG emission reductions
 - Payback time
5. In order to make the case studies as comprehensive as possible, equipment literature on the manufacturers' websites was also consulted to complement the obtained information with technical performance data, product options, and drawings/schematics.
6. For certain case studies, the author estimated energy and GHG emission savings based on BC Hydro bills provided by the owners.
 - For residential electricity rates, BC Hydro rates of \$0.0828 per kWh for the first 1,350 kWh in an average two month billing period was assumed and \$0.1242 per kWh beyond this threshold (BC Hydro, 2017).
 - For GHG estimates, an emission factor of 2.96 kg CO₂e / GJ (0.011 kg CO₂e / kWh) for electricity in BC was used and 49.9 kg CO₂e / GJ for gas (BC MOE, 2016).

8. Case Study Principles, Content & Dissemination

8.1. Principles

All information and data used in the case studies was obtained with the expressed consent of the participants. No participant names, neither of individuals nor companies, are divulged. Only building names and locations are disclosed with the consent of participants.

Case studies have inherent limitations. The case studies in this report represent only a few examples of building retrofits in the Lower Mainland. While such examples are valuable, their generalizability is limited. Each building is different and has specificities that have to be taken into account when considering applying and replicating technology retrofits.

The information contained in these case studies shall not be seen as product or company endorsements. Rather do they represent snapshots of a few implementations of innovative technologies that have been carried out in recent years or are currently planned and that have the potential to reduce building energy consumption, GHG emissions, and to improve indoor comfort.

Any case studies, testimonials, examples, and illustrations cannot guarantee that future users will achieve exactly the same results. Specific building and site factors as well as other circumstances may cause results to vary. While the information, data and quotes contained in these case studies are factual and have been reviewed by participants, the possibility of errors cannot be excluded.

8.2. Content

The retrofit case studies include both building scale technologies and in-suite solutions. Contents vary somewhat depending on the technology type, implementation stage, specific project details, and available information.

The case studies contain descriptions of the buildings and equipment installed, document the performance of the systems and provide a high-level business case of the installation (pre or post-implementation depending on the implementation stage). In addition, they include site pictures and summaries and quotes of interviews with Strata councils, unit owners, maintenance managers, and consultants on the rationale for the technology retrofits and their user experience.

8.3. Dissemination

In addition to being included in this report, the final case studies will be made publically available and disseminated through regional and City channels such as the City of Vancouver website and the forthcoming Metro Vancouver Strata Energy Advisor Program.

9. General Findings

This section summarizes general project results and observations made by the author. The conclusions stem from conversations, meetings, and interviews carried out as part of this project with engineering consultants, manufacturers, utilities, landlords, and Strata council members. These findings are generalizations and will not be applicable to each building and retrofit project.

9.1. Project Results

The retrofit application of HP technologies in MURBs in the Lower Mainland is currently limited. Reaching out to more than 50 different stakeholders to identify MURB projects yielded few examples of completed retrofits. HPs have so far more widely been implemented in new construction projects as well as in some commercial building retrofits. This being said, there is considerable interest in and need for energy efficient retrofits of MURBs. Product innovation and awareness of electrically driven heating and ventilation technologies has increased among industry stakeholders and building owners. All of this hints at the potential of these technologies and the promise of their wider implementation in the near future.

The outcome of numerous inquiries and proactive follow up led to:

- 6 full-length case studies: Four completed and two planned retrofits; out of these six case studies, four are building scale technologies and two in-suite solutions.
- 2 declined case studies: Buildings that did not wish to participate.
- 4 uncertain case studies: Projects that were too early in the consultation process to warrant documentation or that were mentioned but contacts never provided further information.

9.2. Retrofit Motivations

- *Comfort, indoor air quality, maintaining the building condition and raising the property's real estate value* are the biggest reasons why private landlords and Strata councils consider and implement building upgrades. If energy savings can be achieved through retrofits that is an added benefit but generally not the primary concern.
- *Many mid to high-rise MURBs suffer from insufficient ventilation that frequently leads to poor indoor air quality.* Most of these buildings are ventilated using pressurized corridor systems via make-up air units (MAU). These MAUs may not work correctly, be shut off, and are affected by significant air leakage along the ventilation air flow path. Combined, these factors often leave suites under-ventilated and lead to moisture issues.

- *Many MURBs, in particular condos with high glass ratios, need improved heating and cooling.* Residents in north and east facing units frequently desire better heating and those in south and west facing units would like to introduce summer cooling.
- *Different types of building owners have different concerns, retrofit motivations, and mandates.* Their potential funding sources and timelines are also dissimilar. Different stakeholder groups should therefore be targeted individually. For instance, one of the case studies showed that BC Housing disabled HP cooling at the Culloden Court housing site to achieve higher energy savings. The addition of cooling may, however, be one of the main reasons why private building owners may want to consider the installation of a HP.

9.3. Barriers to Retrofits

- *Insufficient spare electrical capacity in many existing buildings is a barrier to the adoption of electrically driven HPs and other technologies.* Electrical upgrades may be required to bring more power from the utility to the building. Such service upgrades also have other benefits including making the property adaptable to future technological advancement, improving safety, and even increase building value.

The electrical panel is the heart of a building's electrical system and the circuits carry electricity to all the plugs, lights, and appliances. Especially in older buildings, the amperage of the electrical panel might need to be increased to accommodate the additional load of a HP. When buildings were constructed several decades ago, electrical panels were installed based on what the expected load would be for the building. Over the years, building appliances have multiplied and existing amperage can therefore be insufficient to add new electrical devices such as HPs. Depending on the chosen technology, electrical upgrades may be required at the building scale, in individual suites, or even at the street level should several buildings on one street consider building-scale technology retrofits.

The costs and details of required electrical upgrades will vary from project to project. The reported or estimated costs for electrical upgrades at different case study buildings ranged from:

- \$100,000 for a central electricity upgrade at the Culloden Court housing site which consists of 88 townhouse units and two apartment buildings (BC Hydro agreed to refund BC Housing some of the central site upgrade costs if other users connect to the service in the future.)
- \$3,000 - \$5,000 for a three storey apartment building with about 40 units (Chimo Terrace).
- \$10,000 - \$15,000 for a high-rise MURB with about 200 units (Discovery Building).

- *HP retrofit business cases for MURBs are frequently unattractive. Paybacks are long.* Many of the technologies featured in the case studies are still relatively immature in North America. Equipment capital costs for building scale technologies are fairly high, in particular in comparison to conventional gas fired

equipment that has been on the market for decades. Installation costs are, however, expected to decrease with wider application.

Another primary reason for challenging business cases for electrically driven equipment are the current energy rates in the Lower Mainland: Low gas prices and comparably higher electricity prices mean that energy cost savings from fuel switching technologies are often not significant. As a result, paybacks for retrofit investments can be long, ranging from a minimum of 10 years to more than 50 years in the case studies. Such long paybacks are generally highly unattractive to private landlords and Strata owned buildings. The building scale equipment that stood out for providing the best business case was hybrid make-up air units (MAUs). This equipment seems to offer reasonable paybacks with good carbon savings and is not very intrusive to the existing building operations to implement.

Overall, to improve business cases, HP retrofits should be planned when the existing heating equipment has reached the end of its lifetime and needs replacement, so that only incremental costs need to be taken into consideration.

- *Private owners, Strata councils and building managers avoid complications, face time constraints, and are unwilling to take risks.* Even when the economics are positive, energy efficient retrofits are frequently declined due lack of time, insufficient technical knowledge, and little experience and help with coordinating retrofit projects. Maintenance managers can also be reluctant to test a new technology and learn how to maintain a new piece of equipment.

9.4. Decentralized, In-suite Solutions

- *The technology of many in-suite solutions has improved and their adoption is surging.* For decades, we have seen decentralized air conditioning units in hotel rooms. Industry professionals typically identify them as "PTAC" - Packaged Terminal Air Conditioners. In recent years, manufacturers have made progress in terms of the efficiency, noise reduction, aesthetics, and ease of installation of these devices. This has spurred their adoption among engineers, landlords, property managers, and homeowners who seek better heating, cooling, and ventilation in their buildings.
- *In-suite heat recovery ventilators (HRVs) can enable energy savings.* When buildings become more air tight due to envelope upgrades, improving ventilation is essential to avoid poor indoor air quality and moisture issues. New decentralized ventilation systems with a heat recovery core use very little energy and provide continuous ventilation without the need for duct work. Such units are not energy savings devices on their own. Their primary purpose is to provide fresh air, where there previously wasn't any, in a manner that avoids the heat loss associated with keeping windows open.

- *In-suite ventilation can overcome the poor performance of corridor pressurization based ventilation systems* that are common in mid to high-rise MURBs. Such devices supply ventilation directly to each suite and are recommended in retrofit applications in conjunction with air sealing of both the exterior building enclosure and interior building zones.
- *Noise can be an issue.* While noise levels are low and new in-suite technologies contain efficient motors and balanced fans, they still produce some noise. Additional noise, no matter how quiet, will be perceptible in any room that previously was silent. There is a risk that sensitive residents will consequently turn the equipment down or completely off, especially if it is installed in bedrooms. Careful consideration of placement and post installation user education are important to avoid this.

9.5. BC Housing

- *The public sector organization is at the forefront of HP retrofits.* BC Housing has undertaken significant capital renewal projects on a number of housing sites with a focus on prolonging the life of these public assets, increasing the energy efficiency, decreasing GHG emissions, and improving comfort. This experience and knowledge of HP retrofits is an asset for industry capacity building and learning across the province.
- *BC Housing generally has a better experience where HPs were installed as hybrid systems with gas back-up.* This is largely due to existing systems being gas fired. Not having to install a new back-up electric heating system limits the cost and complexity of the retrofit project. In addition, electricity prices are higher than gas prices and having access to cheaper gas back-up heating reduces operating costs for BC Housing and tenants.
- *BC Housing can accept higher upfront costs and longer payback periods for its energy efficiency and renewable energy investments.* Due to B.C.'s carbon neutral government mandate, reducing the energy consumption and GHG emissions of their operations has become a priority for BC Housing. This prevents the public sector organization from paying offset charges for the provincial buildings they manage and operate.

10. Recommendations

- *Accelerate market uptake of energy efficiency measures and fuel switching technologies through incentives, price signals, and regulations.* Carefully crafted intervention is needed to push existing residential buildings towards emission reduction measures either as stand-alone projects or integrated with other renewals work.

Develop public incentives to improve the business case and facilitate adoption of HPs and other electrically-driven technologies among MURBs. Such incentives must be carefully crafted and customized to different types of building owners. This includes identifying champions among all stakeholder groups who are early adopters of new technologies, knowledgeable, and respected among their peers and can promote the uptake of HP technologies.

- *Continue to partner and intensify collaboration with utilities to provide retrofit incentives.* BC Hydro is considering extending energy efficiency incentives to fuel switching technologies. A useful enticement they could provide is to pay for and manage electrical upgrades. This would remove a considerable barrier for building owners and Strata council and continue to provide BC Hydro with control over the electrical infrastructure network.
- *Identify pilot projects to verify the performance and costs of hybrid MAUs.* This equipment was identified as the most promising building scale technology in terms of energy and GHG emission savings and payback time. It also has the advantage of offering summer cooling of MURB corridors.
- *Advertise the non-energy benefits of HP retrofits.* Benefits beyond those directly associated with reduced energy use and GHG emissions are often more salient to private landlords and Strata owners. They include improved thermal comfort for residents, enhanced indoor air quality, lower maintenance costs, and potential for higher property values and better insurance rates following building upgrades.
- *Develop turnkey programs to assist building owners in managing the retrofit process.* Such programs could provide project managers who give building owners support and a credible perspective on the technical, financial, and practical aspects of implementing a HP retrofit or large-scale building upgrade. The forthcoming Strata Energy Advisor Program will be aiming to facilitate project management across Metro Vancouver.
- *Carry out further study into the best incentive types, appropriate regulation, and facilitate building energy assessments.* Each building and retrofit context is slightly different and the specificities of the site and all involved stakeholders need to be understood. It is also important to carry out detailed building energy assessments to identify the biggest emitters and understand which buildings have equipment that is soon up for renewal.

11. Case Studies

Case Study 1

Greenbrook, BC Housing – Surrey

Decentralized Air Source Heat Pumps providing space heating and cooling.

Building Description

Address	13450 70b Ave, Surrey
Ownership	BC Housing
Type of Building	Townhouse rows
Year of Construction	1973
Number of units	127

Greenbrook is a 127-unit public housing site for low-income families in Surrey. Built in the early 1970s, the site consists of 28 row-style townhouse blocks and an amenity building. There are 115 three-bedroom units and 12 two-bedroom units, all with full basements.

Approximately 380 people live at Greenbrook, of which a majority are children. In the mid-2000s, the development was selected to be the first carbon neutral BC Housing retrofit project. This aligned with the Province's goal to reduce greenhouse gas (GHG) emissions in BC and to make government operations carbon neutral by 2010.



Greenbrook townhouse row.

Challenge

The housing complex was in poor shape when the province inherited it from the Canada Mortgage Housing Corporation (CMHC). The foundations were leaking, basements were flooding, windows and walls were drafty, heating systems were aging, roofs needed replacing and the building envelopes needed to be sealed. It was decided to save the buildings, in part because so many children lived there. BC Housing accepted the challenge and Greenbrook was chosen as a trial site and model for GHG reductions, energy efficiency, and renewable energy.

Solution

In order to reduce the dependence on fossil fuels as much as possible, electrically driven air source heat pumps (ASHPs) were installed for air heating and cooling, rather than natural gas or baseboard electric heat. Heat pumps (HPs) provide one of the most energy efficient forms of heating because they extract more energy from the air (in the form of heat) than they consume (in the form of electricity). The efficiency of a heat pump is

measured by the coefficient of performance (COP). The COP is the energy output of the heat pump divided by the amount of electricity needed to run the unit. The higher the COP, the more efficient the unit. A properly configured ASHP in a good installation can yield more than three units of heat for each unit of electricity consumed.

At Greenbrook, residents could still augment the ASHPs with electric forced air furnaces - but the idea was for them to pay themselves for augmented heat. The electrical bills for the HPs would be covered by BC Housing.

Other energy and water conservation measures included:

- Exterior wall insulation.
- Double glazed window replacements.
- Solar photovoltaic panels on south facing roofs.
- Heat Recovery Ventilation systems (HRVs).
- High-efficiency electric water heaters.
- Energy efficient light fixtures and water-efficient shower heads and toilets.

The total retrofit project was carried out in two phases: the first one was completed in 2008/09 and the second one in 2010/11.

Original Air Source Heat Pump Installation

Technology	Air-Source Heat Pumps (ASHPs)
Make & Model	HiSEER SHCR24C/32D (24,000 BTU & 32,000 BTU)
Year of Completion	2011
Number installed	128
Service provided	Space heating

A total of 127 HiSEER ASHPs were installed for the entire townhouse complex and an additional unit in the recreation centre. Two different equipment sizes were chosen to fit the two different townhouse floor areas. Four to five heat pumps were set up together at the back of each townhouse row, above the electrical room. HiSEER is a Chinese manufacturer and BC Housing imported the equipment through Trane Canada, a global heating ventilation and air conditioning company.

System Performance & Occupant Behaviour

1/ The HPs were installed with back-up electric furnaces. In the winter, it would take the ASHPs about 3 minutes to reach



Back of Greenbrook townhouse row showing the elevated location of four ASHPs set up next to each other.

the desired temperature. During these first minutes the HPs would distribute cold air into an already cold house. Some tenants did not like this operation mode and consequently raised the temperature at the thermostat by more than 3°C. The way the system was set up was that if tenants raised the temperature in excess of 3°C the backup furnace kicked in as a safety measure— it seemed like an ‘emergency heat call’.

2/ Thermostats were installed in each unit as part of the HP retrofit. Instead of making the temperature regulation simpler, the devices made it more difficult. While the chosen thermostats are not very high-tech, they are more complicated than the mechanical thermostats that had previously been installed.



Typical thermostat installed at Greenbrook.

Many Greenbrook residents are recent immigrants with significant language barriers and some have learning disabilities. For them, transitioning from a simple mechanical thermostat to a digital one was a big shift. BC Housing provided some training but never anticipated the level of education that was required and the many issues that arose.

3/ A thermostat programming fault was discovered in a dozen of townhouse suites: when the HPs were in cooling mode in the summer, the electric furnaces would come on as well. Both systems would be fighting each other.

Because of these combined factors, the electric furnaces came on much more than planned. Many low-income tenants faced high bi-monthly electricity bills, a few exceeding \$500 (instead of \$60-\$70 for those where the HPs worked as intended). Tenant complaints ensued since they couldn’t afford to pay the bills and BC Housing had to step in and settle the bills for them.

These high utility bills prompted BC Housing to look into the technical performance of the equipment. The HiSEER ASHPs showed multiple component failures throughout the entire device: fan blades, bearings, boards, resistors, contacts, and controllers. In addition to the high utility bills, BC Housing’s operations and maintenance department received multiple complaints from different residents about having no heat or no air conditioning. Consequently, the maintenance department had to source replacement parts overseas and through Trane and in the summer 2012 the organization spent more than \$90,000 on repairs for 30 to 40 units.

After 18 months of continuing equipment faults, it became apparent that the model had been discontinued and that no more replacement parts were available. As a result, BC Housing decided to replace all ASHPs at Greenbrook. Since millions of dollars had already been spent on the first large scale retrofit and on equipment repairs, it was not justifiable to replace the units immediately.

Replacement Air Source Heat Pump Installations

Technology	Air-Source Heat Pumps (ASHPs)
Make & Model	Arcoaire HC43H (24,000 BTU and 32,000 BTU)
Year of Completion	2014 - ongoing
Number installed	~ 60 68 to be installed soon
Equipment Cost	\$2,500/HP*128 HPs = \$320,000
Installation Cost	\$1,200/HP*128 HPs = \$153,000

Maintenance Cost	\$75/HP*128 HPs = \$9,600
Annual energy savings	50% (for all measures combined)
Annual energy cost savings	(+) \$5,000
Annual GHG reductions	422 tons CO2e = 96% (for all measures combined)
Payback	44.5 years (originally calculated)

After this challenging experience, BC Housing’s goal was to find equipment that was reliable, widely used in Canada, with replacement parts source-able in North America, and with final assembly completed in North America. Equipment cost was also an important criterion. After a consultation process, the organisation decided to purchase Arcoaire ASHPs since the brand was already widely used in BC and the Lower Mainland and generic parts were easily available. Arcoaire was also the lowest cost brand and model that fulfilled all above criteria. The maintenance department insisted that the same device would be installed in all 127 townhouses because they didn’t want to mix different equipment types on site. Replacement started in 2014 and at the time of writing, about half of all units have been exchanged. The remaining half will be completed in the near future.



Arcoaire ASHP (similar to the HC43H model installed at Greenbrook)

Costs & Maintenance

The regular Arcoaire HC43H model costs about \$3,500/ unit. Due to the high volume purchased by BC Housing, the organisation was able to negotiate a discount and paid about \$2,500/ unit with installation costs amounting to \$1,200 /unit.

With annual maintenance, HPs should last for about 25 years. The most important items to check, that represent common failures, are the thermostat, the reversing valve, making sure that the valve is opening and closing when there is a cooling demand, and checking the refrigerant’s pressure.

Maintenance costs amount to about \$75/ unit annually. BC Housing benefits again from a volume discount since there are 128 units on the Greenbrook site. The new Arcoaire HPs have been successful and reliable. The first units were replaced about three years ago and there have been no issues since then.

Energy Savings

The electric panels in all townhouse rows had to be upgraded to allow for the installation of the HPs, the HRVs and the solar PV panels. All retrofit measures combined, including the insulation measures and window replacements, led to a 50% energy demand reduction for the Greenbrook housing complex.

The new Arcoaire ASHPs have been programmed differently. The 3°C change factor for electric furnaces to come on was removed. Since the HPs now work as intended, tenants’ electricity bills are quite low.

It is noticeable, however, that overall energy costs have increased by \$5K annually. This can be explained by the addition of the summer cooling load (Greenbrook was BC Housing’s first site to receive air conditioning as part of the upgrade). Another factor is the change in energy costs since the retrofit was first planned in the late 2000s: Electricity costs have risen and gas costs have plummeted.

The originally calculated payback for all retrofit measures was 44.5 years. The actual payback will be considerably longer due to the high HiSEER HP maintenance costs and the Arcoaire replacement installations.



Back of Greenbrook townhouse row showing three new Arcoaire HPs (bigger units in grey) and two old HiSEER HPs (smaller units in white).

Thanks to the low carbon electricity in BC, the housing complex's annual GHG reductions targets have been achieved and amount to 422 tons of CO₂e per year, which represents a 96% decrease compared to pre-retrofit emissions. BC Housing designed the solar panels to offset 10% of the annual electricity use of the housing site. All retrofit measures combined likely lead to Greenbrook being net carbon positive.

BC Housing Experience & Lessons Learned

BC Housing's staff learned a number of important lessons from the Greenbrook retrofit. The maintenance supervisor summarizes: *"Greenbrook was a very expensive project where many things went wrong. We learned from these experiences that BC Housing should not use new products and brands, such as the HiSEER heat pumps. The profile of our tenants makes them unsuitable for new technologies. Some of them*

have never operated a thermostat before and simply don't understand how the technology works, even if we put it in the simplest terms. At our sites, we need to use what is tried and tested and has longevity."

He also explains that subsequent heat pump retrofit projects have not been complete fuel switches: *"We learned from this project that natural gas back up is important. Maintenance requirements for heat pumps are often higher than we anticipated and electric back up heating is expensive."*

BC Housing's energy manager adds: *"The change in energy costs that we have seen over the last ten years was unpredictable. When we designed the Greenbrook retrofit, electricity prices were lower and gas prices were higher. The anticipated payback time was quite different."*

"Another point is that the heat pumps introduced cooling in the summer and that was not thought out very well. They were only supposed to provide cooling above 27°C outside but our tenants quickly found out that they could override that. So the heat pumps will frequently never shut off in the summer time to provide cooling. Because the tenants are not paying the heat pump electricity bills there are certainly abuses", explains the maintenance supervisor. To prevent replication, BC Housing has disabled the cooling function at other heat pump retrofit sites.

When asked about potential noise issues associated with the ASHPs, the maintenance manager reveals: *"The specific design at Greenbrook, where the HPs are raised and put at the end of each townhouse, is not ideal. They were placed above the electrical rooms. In all other developments we have we put them in the back yard. But the noise factor is still minimal if you are inside because the envelope was retrofitted so well; this part was designed well."* *"The fan noise is all you are hearing and that is typical for all air source heat pumps. I don't think there is a big difference between the old HiRSEER and the new Arcoaire models."* Overall, there have not been many noise complaints.

Applicability

ASHPs can be widely applied to different building types to provide space heating and cooling. At 10°C, the COP of ASHPs is typically about 3.3. This means that 3.3 kilowatt hours (kWh) of heat are transferred for every kWh of electricity supplied to the heat pump. The COP decreases with temperature because it is more difficult to extract heat from cooler air. The local mild climate makes the Lower Mainland an ideal geographic area for their application.

HP retrofits are generally easier to implement in townhouse style buildings and single-family homes, in particular in wood-frame construction. Building scale HP applications for mid and high-rise multi-unit residential buildings tend to be more complex.

Thanks to their efficiency, the operating energy costs of an ASHP can be lower than those of other heating systems, particularly electric resistance heat or oil heating systems (which are limited in the Lower Mainland). Proper maintenance is critical to ensure that the HP operates efficiently and has a long service life.

As a Crown agency of the British Columbia provincial government, BC Housing needs to comply with the carbon neutral government mandate and reduce GHG emissions by conserving electricity and fossil fuels. This allows the organisation to be a pioneer in energy efficient retrofits and take longer payback periods into account than most private landlords or Strata organisations.

Limitations

This type of equipment has a number of limitations that need to be considered depending on building specificities:

- Sufficient outdoor space is required which can sometimes be difficult in retrofit applications. In particular, ASHPs require outside air to operate and should not be covered.
- The colder it gets outside the less efficient ASHPs get, declining rapidly from 1°C and generally being unable to heat a building at minus 15°C. Therefore, they require a backup heater that is large enough to heat the entire building on the coldest days of the year.
- Existing buildings often have insufficient electrical capacity for ASHPs which means that upgrades would be required for their application. This will increase the installation costs.
- Equipment capital costs can be high, in particular for mid to high-rise residential building-scale solutions. Due to current low gas prices and comparably higher electricity prices, paybacks can be long, especially in comparison to gas-fired boilers or furnaces. To mitigate this, HP retrofits should be planned when the existing heating equipment has reached the end of its lifetime and needs replacement so that only incremental costs need to be taken into consideration.
- In buildings that did not have air conditioning prior to the retrofit, the introduction of summer cooling loads will reduce energy savings, but can be a highly desirable co-benefit for residents - and in some cases could be the primary motivation for installing a heat pump.
- Although today's ASHPs are significantly quieter than previous generations, the noise generated by the fans can still be an issue and the placement of the HP therefore needs to be carefully considered.

Case Study 2

Culloden Court, BC Housing – Vancouver Decentralized Air Source Heat Pumps for space heating.

Building Description

Address	6265 Knight Street, Vancouver
Ownership	BC Housing
Type of Building	Townhouse rows
Year of Construction	late 1960s
Number of units	88

Culloden court is a public housing site in Vancouver that provides family and retirement home residences. Built in the late 1960s, the housing complex consists of 88 townhouse units that are arranged in rows and two medium sized apartment buildings. The townhouse units are dedicated to low-income families and are made up of two to five bedroom units and also include a few bachelor suites. The separate apartment buildings offer senior residents independent living options.



Townhouse row at Culloden Court.

Retrofit Context

In late 2009, the Governments of Canada and British Columbia launched the Housing Renovation Partnership, a jointly funded program to renovate and retrofit social housing. Over the following three years, the majority of approximately \$164 million of funding was directed toward repairs and energy efficiency upgrades at 81 social housing developments.

The governments had multiple objectives. First, to improve the quality of life for residents by keeping their homes safe and affordable as well as extending the building lifetimes. Second, to fulfil the carbon neutral government mandate by reducing public operations' energy consumption and greenhouse gas (GHG) emissions. Third, during a time of economic recession due to the financial crisis, the larger objective of the governments was also to stimulate the B.C. economy through the creation of construction and trades jobs. Culloden Court was among the sites selected for mechanical equipment improvements and a renewable energy installation.

Solution

In order to reduce the dependence on fossil fuels as much as possible, electrically driven air source heat pumps (ASHPs) were selected as the main source for space heating at the townhouses. Heat pumps (HPs) provide one of the most energy efficient forms of heating because they extract more energy from the air (in the form of heat) than they consume (in the form of electricity). This means that most of the energy for heating comes

from the external environment (the air); only a fraction comes from electricity. HPs move heat instead of generating heat by circulating a substance called a refrigerant through a cycle of evaporation and condensation.

A HP’s efficiency is measured by the coefficient of performance (COP). In electrically-powered HPs, the heat transferred can be three or four times larger than the electrical power consumed, giving the system a COP of 3 or 4.

The reason that it appears that more energy is being produced than is consumed, is because the only “valuable” energy input is electricity used to drive the compressor and circulating pumps. The remainder of the energy is simply transferred from a heat source that would otherwise not be used—the ambient air—and is not considered as an energy input.

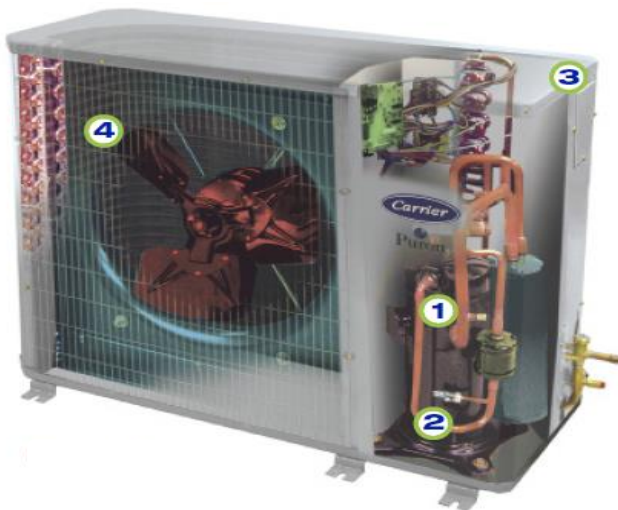

- 1... Compressor
- 2... Piping through which the refrigerant runs in cycles of evaporation and condensation.
- 3... Armor protection shields the outdoor unit from precipitation and other hazards.
- 4... Fan

Cross section diagram of Carrier heat pump model #38QRR.

At Culloden Court, an ASHP was installed in the backyard of each townhouse unit. In addition, solar thermal collectors were retrofitted at the two apartment buildings that house seniors for domestic hot water heating. Solar thermal technology uses the sun’s energy to generate low-cost, environmentally friendly thermal energy.

Project Details

Technology	Air-Source Heat Pumps
Make & Model	Carrier (similar to model #38QRR)
Year of Completion	2013
Number installed	88
Equipment cost	\$5,000/HP*88 HPs = \$440,000
Installation cost	\$4,000/HP*88 HPs = \$352,000
Electricity upgrade cost (central upgrade for site)	\$100,000
Maintenance cost	\$75/HP*88 HPs = \$6,600
Annual energy cost savings	\$20,000
Annual GHG reductions	154 tons CO2e = 38%
Payback	44.6 years

Culloden Court was part of BC Housing's first energy service company (ESCO) projects. An ESCO is a commercial or non-profit business providing a broad range of energy solutions including design and implementation of energy savings projects, retrofitting, energy conservation, and risk management. As part of this project, two different consultants' proposals were requested and Carrier ASHPs was the equipment recommended by them. Carrier is an American company that manufactures and distributes heating, ventilating and air conditioning (HVAC) systems worldwide.

A total of 88 ASHPs were installed in each townhouse back yard between 2012 and 2013. Two different equipment sizes were selected to fit the different townhouse floor areas. The existing gas furnaces were less than 10 years old when the project was completed. Since they were operating well, they were left in place to provide back-up heat during the coldest times of the year.



Air source heat pump installed in the back yard of a townhouse unit at Culloden Court.

All ASHPs' efficiency declines when outside temperatures drop. At Culloden Court, the Carrier ASHPs operate until an outside temperature of 4°C; below this temperature the gas furnaces kick in, which is on average only about 10% - 15% of the year in Vancouver's mild climate. This means that for the vast majority of the year electricity and the heat captured from the ambient air provide the primary sources of heating.

BC Housing's experience with other HP retrofits showed that the equipment worked more efficiently, leading to greater energy savings, if the organisation kept more control over the devices centrally. As a consequence, a direct digital control system was installed so that BC Housing's maintenance department could remotely control all equipment. This means that a computer regulates both the ASHPs and gas furnaces based on the input the maintenance department provides regarding when the devices should come on and off and at what level they should operate.

In addition, it was decided for the HPs to only provide space heating and the cooling mode was deactivated. Residents can still control the inside temperature of their units through simple mechanical thermostats.

Costs & Maintenance

The regular price for this type of residential Carrier ASHP is about \$5,000/ unit. It is likely that BC Housing negotiated a volume discount for this project but these details have not been disclosed. Installation costs amounted to about \$4,000/ unit including engineering work and electricity upgrades.

The electrical panel is the heart of a building's electrical system and the circuits carry electricity to all the plugs, lights, and appliances. Especially in older buildings, the amperage of the electrical panel might need to be increased to accommodate the additional load of a heat pump. When



Typical thermostat installed at Culloden Court.

buildings were constructed several decades ago, electrical panels were installed based on what the expected load would be for the building. Over the years, building appliances have increased and existing amperage can therefore be insufficient to add new electrical devices such as heat pumps. Electrical upgrades may be required to bring more power from the utility to the building.

At Culloden Court, there was an additional cost of approximately \$100,000 to upgrade the central electrical service for the entire housing site. BC Hydro agreed with BC Housing they may be refunded some of that expense if other users connect to this new service in the future. The total initial up front cost for BC Housing for this space heating system retrofit was about \$892,000.



Example of an integrated air source heat pump with the back yard furniture of one of the townhouse units at Culloden Court.

With annual maintenance, HPs should last for about 25 years. Maintenance costs amount to approximately \$75/ unit annually thanks to the organisation benefiting from a volume discount. BC Housing's operations department takes care of all the equipment maintenance so the tenants don't need to intervene.

The new Carrier ASHPs' operation has been successful and reliable. Since the first devices were installed in 2012, about 10% have had some minor maintenance issues or failures, which is quite low. The advantage of this particular retrofit heating system design is that the existing gas furnaces were left in place and BC Housing controls the system centrally. This means that if a HP fails, the gas furnace can be switched on and the tenants don't notice any interruption or change.

Energy Savings

New electric panels had to be installed in all townhouses to provide sufficient electrical capacity

for the HPs. Due to building code requirements in 2012, new Make-up Air (MAU) units also had to be installed in each basement at the time of renovation. The MAU units conformed with code requirements which means that they were oversized for the new efficient ASHPs and the now reduced use of the gas furnaces. This results in more cool and fresh air being blown into each suite than would be necessary, and reduces the energy savings. In terms of the utility bills, a few tenants initially complained that their electricity bills had increased after the ASHP installation. In the long run, however, the HPs have increased tenants' awareness to use electricity more sparingly. They pay more attention to the temperature setting and turn the device down or off before they leave the house.

Overall, the total energy cost savings from the HP retrofits have been significant: BC Housing saves about \$20,000 annually in utility costs; the anticipated payback time for the investment is 45 years. This positive outcome is in part also due to the performance contract that was established between BC Housing and the ESCO.¹ In addition, thanks to the low carbon electricity in BC, the housing complex's annual GHG reductions targets have been achieved and amount to 154 tons of CO₂e, or 38% per year.

¹ ESCOs performance contracting is a means of raising money for investments in energy efficiency that is based on future savings. This approach is typically applied to retrofitting an existing building. In such a situation, an ESCO agrees to provide the owner with a set of energy efficient technologies and equipment, and usually arranges the financing to pay for the upgrades so that the owner has to provide little or no capital. Instead, the ESCO takes on the upfront cost and associated risk, and the money saved on energy bills as a result of the retrofits is used to pay the company back until the cost is covered. Many energy performance contracts even include performance guarantees, meaning that payment is contingent upon demonstrated energy savings.

BC Housing Experience & Lessons Learned

BC Housing is satisfied with the performance of the ASHPs and considers the retrofit a success. *“It took a while to get used to the system programming and configure it properly but now it runs smoothly. The advantage of leaving in the existing back-up gas furnaces is that if there are any issues with the heat pumps, we can easily turn them off and provide gas heating in the interim which comes on quickly and is not expensive,”* explains the maintenance supervisor.

He adds further: *“The big difference to Greenbrook, another air source heat pump retrofit project that we completed at a townhouse complex before, is that the heat pumps at Culloden Court are set to only provide heating, not cooling. This way our energy savings are bigger - this was one of the take-aways from Greenbrook.”* In contrast to BC Housing, the addition of cooling that heat pump technologies provide may be one of the main reasons why other building owners consider the installation of a heat pump.



Central yard with playground at Culloden Court.

All HPs produce noise when running due to their components, mainly stemming from the compressor and fan. Generally, there are many misconceptions about the amount of sound heat pumps make and many different claims from manufacturers about what their units do. Overall, the technology has improved and noise levels have decreased. Today, noise levels of common residential models for single family dwellings and townhouses range between 40 dB to 50 dB, which is roughly equivalent to the interior of a library or a running stream. The Carrier model # 38QRR, which is similar to the one installed at Culloden Court, specifies a maximum noise level of 68 dB. The placement of the ASHP is therefore very important.

When asked about potential noise issues associated with the ASHPs at Culloden Court, the site manager reports: *“We haven’t had any noise complaints from the tenants because the HPs are placed in the back yards which the tenants don’t seem to use much.”* She adds, *“My husband and I use our yard quite a lot. We spend much time outside, all year round. Because we often sit next to the heat pump, I sometimes turn it off.”* Since the HPs only operate in the winter and shoulder seasons, when residents spend less time outside, the noise produced by the HPs is not an issue for the majority of the residents.

In the case of the BC Housing ESCO project, the two levels of government provided all of the funding for upgrades, savings guarantees were provided by the ESCO for the whole portfolio of buildings that they were responsible for upgrading, and if savings targets had not been met for the portfolio, the ESCO would be responsible for paying a lump sum equal to the amount of predicted savings over 10 years. As savings were achieved for the portfolio after three years of analysis, no payment was required.

Applicability

ASHPs can be widely applied to different building types to provide space heating and cooling. At 10°C, the COP of ASHPs is typically about 3.3. This means that 3.3 kilowatt hours (kWh) of heat are transferred for every kWh of electricity supplied to the heat pump. The COP decreases with temperature because it is more difficult to extract heat from cooler air. The local mild climate makes the Lower Mainland an ideal geographic area for their application.

HP retrofits are generally easier to implement in townhouse style buildings and single-family homes, in particular in wood-frame construction. Building-scale HP applications for mid and high-rise multi-unit residential buildings can be more complex.

Thanks to their efficiency, the operating energy costs of an ASHP can be lower than those of other heating systems, particularly electric resistance heat or oil heating systems (which are limited in the Lower Mainland). Proper maintenance is critical to ensure that the HP operates efficiently, to keep the noise level to a minimum, and to preserve its service life.

Limitations

This type of equipment has a number of limitations that need to be considered depending on site and building specificities:

- Sufficient outdoor space is required which can sometimes be difficult in retrofit applications. In particular, ASHPs require outside air to operate and should not be completely enclosed.
- The colder it gets outside the less efficient ASHPs get, declining rapidly from 1°C and generally being unable to heat a building at minus 15°C. Therefore, they require a backup heater that is large enough to heat the entire building on the coldest days of the year.
- Existing buildings often have insufficient electrical capacity for ASHPs which means that upgrades can be required for their application. This will increase the installation costs.
- Equipment capital costs can be high, in particular for mid to high-rise residential building-scale solutions. Due to current low gas prices and comparably higher electricity prices, paybacks can be long, especially in comparison to gas-fired boilers or furnaces. To mitigate this, HP retrofits should be planned when the existing heating equipment has reached the end of its lifetime and needs replacement, so that only incremental costs need to be taken into consideration.
- In buildings that did not have air conditioning prior to the retrofit, the introduction of summer cooling loads will reduce energy savings, but can be a highly desirable co-benefit for residents - and in some cases could be the primary motivation for installing a heat pump.
- Although today's ASHPs are significantly quieter than previous generations, the noise generated by the fans can still be an issue and the placement of the HP therefore needs to be carefully considered.

Case Study 3

Chimo Terrace, BC Housing – Vancouver Centralized CO2 Heat Pumps for domestic hot water.

Building Description

Address	2080 and 2120 Wall Street, Vancouver
Ownership	BC Housing
Type of Building	Two 3-storey apartment buildings
Year of Construction	1970
Number of units	80

Chimo Terrace is a seniors affordable housing complex in Vancouver owned and operated by BC Housing. The housing complex offers senior residents independent living options as well as a variety of amenities and services. Built in 1970 out of wood-frame construction, the site consists of two three-storey buildings. There is a total of 80 rental suites and about 85 seniors live in each building. Both structures are very similar in size and layout: Each suite has its own kitchen and bathroom facilities with the clothes washing machines and dryers being centralized in a common area.



Outside one of the apartment buildings at Chimo Terrace.

Retrofit Motivation

Sustainability is at the core of BC Housing’s social housing and homeowner protection mandate and a key component of their business strategy. The organisation’s largest source of greenhouse gas (GHG) emissions is from social housing sites that they own or manage. As a Crown corporation of the British Columbia provincial government, BC Housing needs to fulfil the carbon neutral government mandate which is predominantly achieved by reducing its operations’ energy consumption and GHG emissions.

In 2016, BC Housing hired two engineering consulting companies to assess Chimo Terrace’s building condition and current energy consumption, with the objective of identifying the most suitable energy efficiency upgrades. The first company carried out a detailed energy study and outlined low and high-cost energy conservation measures. The second firm focused on the feasibility of the measures and was asked to more specifically identify mechanical service improvements that will achieve 50% GHG emission reductions compared to existing levels. Several findings of these two reports are summarized in this case study.

Energy Consumption & Benchmarking

There are two mid-efficiency gas boilers in each building that provide hot water to hydronic radiators for space heating and through heat exchangers for domestic hot water (DHW). There are no temperature controls in the suites. Pumps support the heating loop, heat exchanger and DHW.

Corridor make-up air for the buildings is provided by 12 supply fans, six for each building, serving levels 1 to 3. These ventilation fans are cabinet fans which bring in outdoor air and discharge it into the corridors, with no heating. The majority of these hallway ventilation fans are, however, not working. Suites have washroom exhaust fans and range hoods which are controlled by on/off switches and discharge air outdoors.

The energy study showed that Chimo Terrace's energy intensity is above average social assistance buildings in BC and Canada. The percentages of electrical and gas consumption by building system, in equivalent units of energy, are presented in the adjacent figure. It is important to note that tenant electricity consumption is separately metered and was not included in the energy study. The common area plug load is particularly high as it includes the shared laundry dryers.

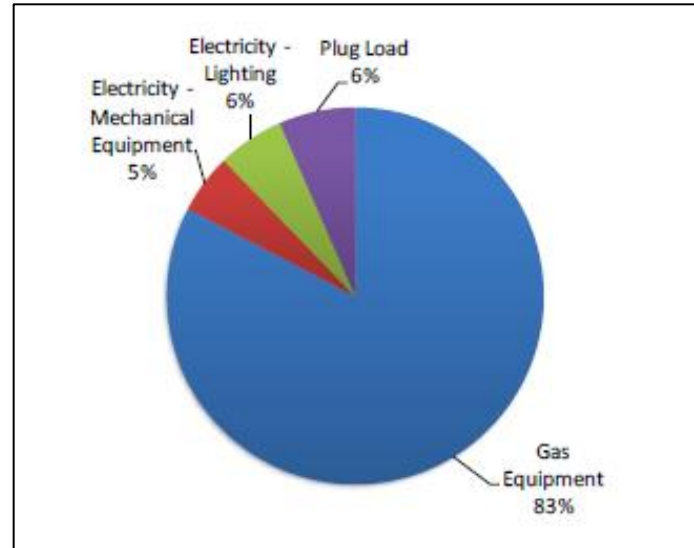

Total energy consumption split at Chimo terrace.

Gas equipment accounts for approximately 83% of the total building energy consumption. From this energy profile, it was estimated that the buildings currently produce about 219 tons of annual CO₂e emissions, excluding tenant electricity. Since BC's electrical power is largely provided by hydro energy, additional GHG emissions from the tenants' electricity use is very low. The vast majority of GHG emissions related to the operation of the housing site stem from centralized gas fired equipment. As a result, the consultants focused on energy conservation opportunities that would reduce gas consumption. The analysis showed that the current DHW provision by heat exchangers from the gas boilers is particularly inefficient in the summer when little hydronic heating is needed.

Proposed Solution

In order to reduce the dependence on fossil fuels as much as possible, the first assessment report recommended electrically driven, centralized air to water heat pumps (HPs) to provide DHW for each building. It was hoped that this option would allow the boilers to be shut off when space heat is not required, thereby considerably reducing natural gas consumption. In addition, this solution would capture boiler room heat and transfer this heat to the DHW system.

The second consulting firm examined the proposed solution in greater detail and recommended a new heat pump water heater technology. The Sanden SANCO₂ water heater system warms water by transferring the heat from the surrounding air to the water using a refrigerant. The system consists of two parts: The outdoor unit, where the hot water is produced, using the refrigerant to extract heat from the ambient air, and a storage tank, which is usually installed inside the building.

What is innovative about this system is the CO₂-refrigerant: HP water heaters commonly use synthetic refrigerants, such as R410A or R134A. Although these refrigerants do not deplete the ozone layer, they can have a significant impact on global warming. The CO₂ refrigerant used in the SANCO₂ system has a very low Global Warming Potential², and CO₂, a natural refrigerant, does not deplete the ozone layer.³

² Global Warming Potential (GWP) is a measure of how much a given mass of greenhouse gas is estimated to contribute to global warming. It is a relative scale which compares the gas in question to that of the same mass of carbon dioxide (whose GWP is equal to 1).

³ For comparison, the refrigerant R410A has a GWP of 1725 and refrigerant R134A has a modest GWP of 1300.

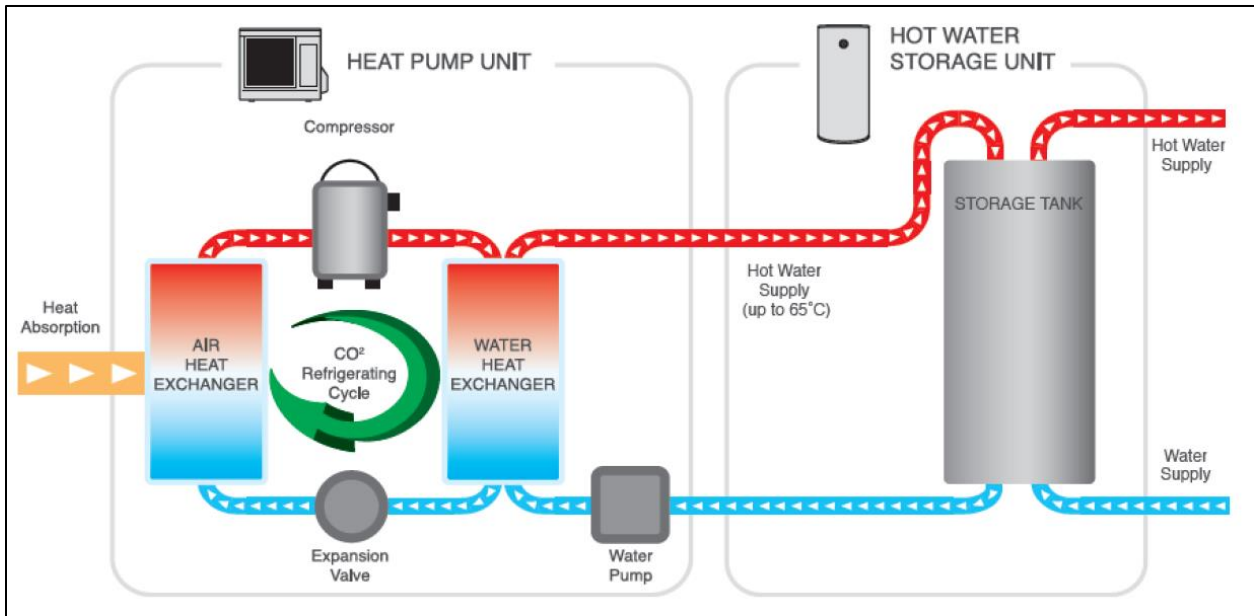

Schematic of the Sanden CO2 heat pump water heater system.

In addition to the ozone-friendly refrigerant, the SANCO2 equipment offers a number of other advantages in comparison to conventional hot water HPs:

- A high Coefficient of Performance (COP); the COP is the energy output of the heat pump divided by the amount of electricity needed to run the unit. The higher the COP, the more efficient the unit.
- An extended operating range with hot water production from -26°C to 43°C ambient outside temperatures.
- Delivered hot water temperature of 65°C (149°F).
- No need for back-up electric elements in the storage tank.
- Low operating noise of 38 dB (similar to whispering noise).

HPs lose efficiency when outdoor temperatures drop. The following table and graph show how the SANCO2 HP's capacity and COP change at different outside temperatures.

Ambient		Capacity	COP
°C	°F	Kw	
-25	-13	3.5	1.7
-20	-4	4.0	2.0
-15	5	4.5	2.2
-10	14	4.5	2.5
-5	23	4.5	3.0
0	32	4.5	3.2
5	41	4.5	3.7
10	50	4.5	4.5
15	59	4.5	4.7
20	68	4.5	5.2
25	77	4.5	4.9
30	86	4.5	4.6
35	95	4.6	4.4
40	104	4.6	4.0
45	113	4.7	3.8

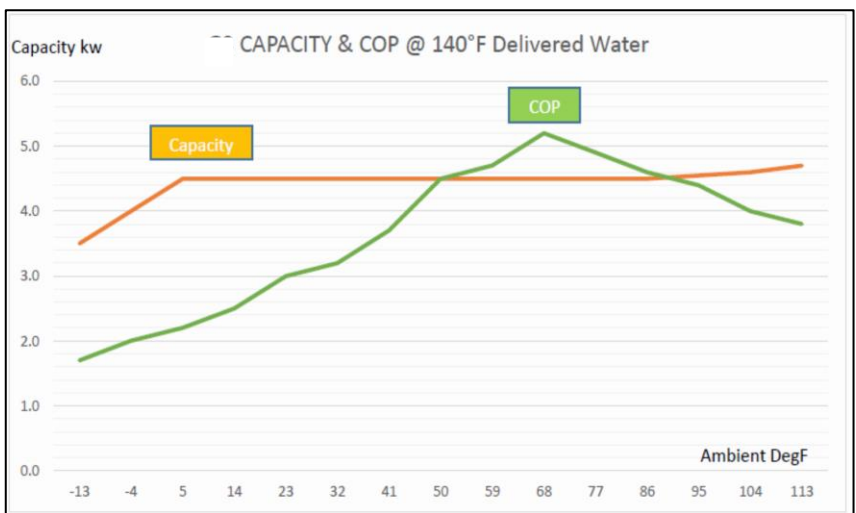

SANCO2 Heat Pump capacity and COP at different ambient outside temperatures.

Proposed Project Details

Proposed System Design

Technology	CO2 Heat Pump
Make & Model	Sanden SANCO2 GUS-A45HPA Large storage tank (83 gal): GAUS-315EQTD
Number to be installed	12 heat pumps & 12 storage tanks (6 per building)
Water Temperature Setting	65°C (149°F)
Ambient Air Operating Temperature	-26°C to 43°C (-15°F to 110°F)
Heat Pump Capacity	4.5 kW (average)
Coefficient of Performance (COP)	4.5 (average)
Refrigerant Type	R744 (CO2)
Power Voltage	208/230 V
Outdoor Noise Level	38 dB

The CO2 hot water heater system is currently only available in a smaller, single family residential capacity. To provide enough DHW for each apartment building at Chimo Terrace, it was calculated that six HPs and six large 83 gallon storage tanks would have to be installed in series at each building.

Detailed system sizing calculations showed that the existing gas boilers would likely still be required to operate in the summer to meet the peak DHW demands. The concept is to have the DHW make-up run through the six HPs in parallel and then through the existing heat exchanger to get topped off as necessary.

This would mean connecting the new HPs to the existing DHW heating system. The HPs would cycle on as required to maintain the temperature set point in the new storage tanks. The key is to take cold make-up water into the HPs and circulate the DHW from the heat pumps into the existing DHW heating loop. Then, if the HPs can't keep up with demand, the existing gas boiler would come on to provide additional heating.

The new HPs would be mounted at the rear of each building, against the back wall. A covered area that currently provides parking would be used to house the water storage tanks in a semi-heated room.



Covered parking area which would be used to house the storage tanks.



Outside area where the CO2 heat pumps are planned to be placed.

Estimated Costs

Equipment cost	\$5,000/HP incl. storage tank = \$60,000
Installation cost	\$3,500 - \$4,500/ HP*12 = \$42,000 - \$54,000
Electrical upgrade cost	\$3,000 - \$5,000/ building*2 = \$6,000 - \$10,000
Maintenance cost	not yet known
Annual energy savings (gas)	1,270 GJ
Annual energy cost savings	\$2,000
Annual GHG reductions	63.1 tons CO2e (28%)
Payback	54 - 62 years
Project Status	to be tendered in 2017

The regular price for the Sanden CO2 HP including the large storage tank is approximately \$5,000/ unit. At Chimo Terrace, 6 HPs and 6 storage tanks would be required per building, resulting in 12 equipment pairs altogether at a price of \$60,000. The anticipated installation costs are likely to be about \$3,500 - \$4,500 /HP and storage tank including piping, mounting, electrical services and controls. In addition, the electrical systems at each apartment building are currently at their maximum capacity - upgrades would therefore be required to accommodate the new devices. The electrical panel is the heart of a building's electrical system and the circuits carry electricity to all the plugs, lights, and appliances. Especially in older buildings, the amperage of the electrical panel might need to be increased to accommodate the additional load of a heat pump. Costs for such upgrades are estimated to be about \$3,000 - \$5,000 / building. The total investment cost for BC Housing for this new DHW HP system at Chimo Terrace would therefore be about \$55,000 - \$65,000 / apartment building. The expected lifetime for the SANCO2 HPs is about 20 - 25 years.

Estimated Energy Savings

At the time when the energy study was completed, energy savings from DHW HPs were estimated to be about 1,270 GJ of gas annually. Due to the current low cost of gas, this would only translate into annual energy cost savings of about \$2,000. The GHG emission reductions that would result from this gas cutback are estimated to be 63.1 tons of CO2e, about 28% of total building GHG emissions. It is noteworthy that these estimates were made under the assumption that the existing gas boilers could be shut off when space heat is not required.

As mentioned above, later calculations of the specific system design showed that the existing gas boilers would likely still be required for peak DHW demand in the summer. Consequently, gas and GHG savings would likely be diminished. Moreover, Chimo Terrace's current gas boilers and hot water tanks are fairly new and don't need replacement. If the project, in its current design, was implemented today the payback would be around 54 to 62 years. The shortfall of achieving the desired GHG savings, coupled with the long payback period, makes the current design of the proposed mechanical equipment retrofit unattractive to implement.



SANCO2 Heat Pump and Storage Tank.

Barriers

BC Housing recognizes that the complexity of the system—attaching six HP units and storage tanks in series—poses a significant challenge to the proposed solution. In addition, a heated mechanical room would have to be built outside for the devices, including running about 30 feet of exterior piping. The manufacturer is supposed to soon launch a larger DHW system, more applicable to multi-unit residential buildings, which could replace the entire gas fired hot water heating system of an apartment building. New larger storage tanks are currently in approval testing. BC Housing is therefore planning to wait for the larger CO2 HPs to be available before implementing the proposed retrofit.

BC Housing Feedback

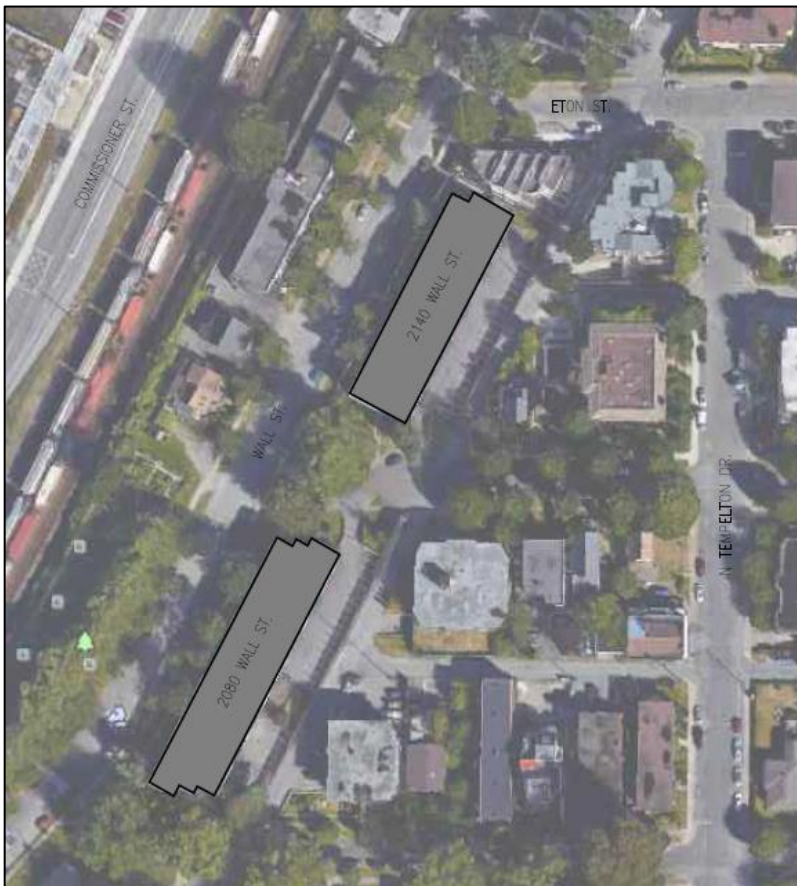

Bird's eye view of the two apartment buildings that make up the retirement home complex called Chimo Terrace.

BC Housing's project manager explains: *"We would like to use Chimo Terrace as a demonstration project for this new technology. However, given the complex system design with six heat pumps and storage tanks attached in series, the projected implementation costs are very high."* He adds: *"We are likely to put the project out for tender at the end of 2017. One of the options we consider is to only install the CO2 heat pumps in one of the buildings to reduce the project cost. By doing so, we'll have an opportunity to see how the technology operates and compare between two very similar buildings, whether the promised GHG savings are actually achieved."*

The project manager reports further: *"At Chimo Terrace, we are also planning to improve the ventilation controls to introduce a heated air exchange to the building. Such a system would likely consist of a new supply fan with a heating coil. This heating coil could then be connected to the hot water system."* *"The current proposed system design for the CO2 hot water heat pumps is less attractive because the existing gas boiler would still remain as back-up in the summer time to supplement the heat pumps. Once the larger units are*

available, this will simplify the concept and likely allow us to reach the desired GHG emission reductions we would like to achieve with the site retrofit. It will probably make most sense to wait with the project's implementation."

Applicability

The CO₂ HP water heater system is a very energy efficient alternative to traditional electric or gas water heaters and promises to save money and reduce GHG emissions. In its current design and capacity, the equipment can be widely applied to single family and townhouse homes and is relatively easy to install for these building types.

Since the HP unit is installed outdoors, up to 25 feet away from the indoor tank, and operates at a very low noise level, the system has potentially a greater number of acceptable placement locations than conventional ASHPs.

While it is true that the COP decreases as temperatures decline because it is more difficult to extract heat from cooler air, the extended operating range of the SANCO₂ model makes the equipment more applicable for use in colder climates than conventional air source heat pumps. Given the local mild climate, the Lower Mainland is an ideal geographic area for the equipment's application.

The CO₂ HP hot water heater system is a very promising technology and retrofit solution. Once larger systems and capacities are commercially available, the equipment's application can be more easily extended to multi-unit residential buildings.

Limitations

This type of equipment has a number of limitations that need to be considered depending on site and building specificities:

- This innovative technology has only recently been introduced to the North American market and there is a lack of real world data due to its limited implementation so far. Over time, more widespread application will show whether the CO₂ HPs actually perform at an average COP of 4.5 in the Lower Mainland's climate. Should this be the case then they represent a viable alternative to natural gas heaters. However, if the average COP is lower than 4, the business case will suffer.
- The colder it gets outside the less efficient HPs get. Depending on the heating load of the building and how the HP system is sized, the CO₂ HPs offer the possibility of delivering adequate hot water even at low outside temperatures. The problem is that in cold climates more electricity will be required for the DHW delivery since the unit's COP declines. This will increase operating costs and thereby hurt the business case.
- Since the technology is relatively immature in North America, equipment capital costs are currently fairly high. Up-front costs are, however, expected to decrease with wider application. Due to today's low gas prices and comparably higher electricity prices, paybacks can be long, especially in comparison to gas water heaters. To mitigate this, HP retrofits should be planned when the existing heating equipment has reached the end of its lifetime and needs replacement, so that only incremental costs need to be taken into consideration. BC Housing's approach taken is an exception to this principle. In contrast to private owners, the public sector organisation can afford higher upfront costs and longer paybacks due to its carbon neutral mandate.
- Sufficient outdoor space is required which can sometimes be difficult in retrofit applications. In particular, HPs require outside air to operate and should not be completely enclosed.
- Existing buildings often have insufficient electrical capacity for HPs which means that upgrades can be required for their application. This will increase the installation costs.
- CO₂ HPs currently have insufficient capacity for applications in multi-unit residential buildings. Larger devices are in approval testing and should be available in the near future.

Case Study 4

Discovery Building – Vancouver

Hybrid Air Source Heat Pump for Make-up Air Ventilation & Heating.

Building Description

Address	1500 Howe Street, Vancouver
Ownership	Condo, Strata Council
Type of Building	High-rise multi unit residential
Year of Construction	1989
Number of units	176

Built in 1989, the Discovery Building was one of the first high density residential projects constructed in Vancouver’s False Creek North neighbourhood. It is a 24 storey, concrete high rise building situated along the seawall in the Downtown peninsula. The condo consists of retail units on the street level and provides a total of 176 residential units, ranging from studio to three bedroom suites. The building offers residents a variety of amenities and services such as meeting rooms, a gym, and a whirlpool and sauna.

Retrofit Motivation

In 2016, the building was selected as a suitable candidate site for a pilot project to test a new ventilation heating technology that promises to reduce energy consumption and greenhouse gas (GHG) emissions. Since none of the condo’s mechanical equipment has been replaced since the building was constructed 28 years ago, the existing make-up air unit (MAU) has reached the end of its lifetime. MAUs supply fresh air to buildings to compensate for air lost through exhaust fans and other sources. Simply put, they “make up” for lost air, which helps to ensure good indoor air quality for residents. The existing equipment is gas fired and located on the roof of the building. Because the MAU needs to be replaced in the near future, now is the time to examine more energy efficient options that have been developed since the existing unit was installed in the late 1980s.

Existing mechanical equipment

The Discovery Building’s ventilation is supplied via a conventional MAU situated on the roof. The unit has a fan that draws in fresh outdoor air. Since winter air is very cold, the MAU has a gas-fired heater to warm up the air before it enters the building. The equipment is connected to a central corridor duct system that supplies heated air into the common areas. Pushing air into a building positively pressurizes the corridors on each floor. When the corridors are pressurized, the air looks for a way to get out. Every suite door therefore has undercuts to allow the air to escape the corridor and enter the suite. This new air will make up for that lost through kitchen hood fans, bathroom exhaust fans and open windows in the suites, and provide fresh air for a healthier indoor environment.



The Discovery Building from Beach Avenue.

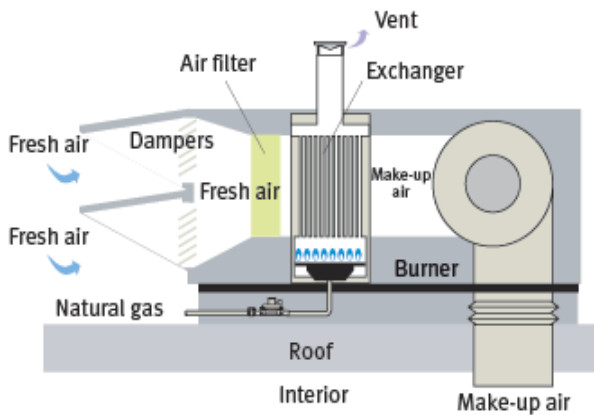

Heated air
supplied
to building

Existing Scenario: Schematic and picture of a conventional gas fired make up air unit.

Many odour problems in buildings can be attributed to the so-called stack effect. If the rooftop MAU is not operating, or is turned down too low, air and odours from suites (and from the garbage chute shaft if one exists) will escape into the upper floor corridors. MAUs help temper the stack effect by pressurizing the corridors and holding back any air that is trying to escape existing shafts (see schematic diagram below).

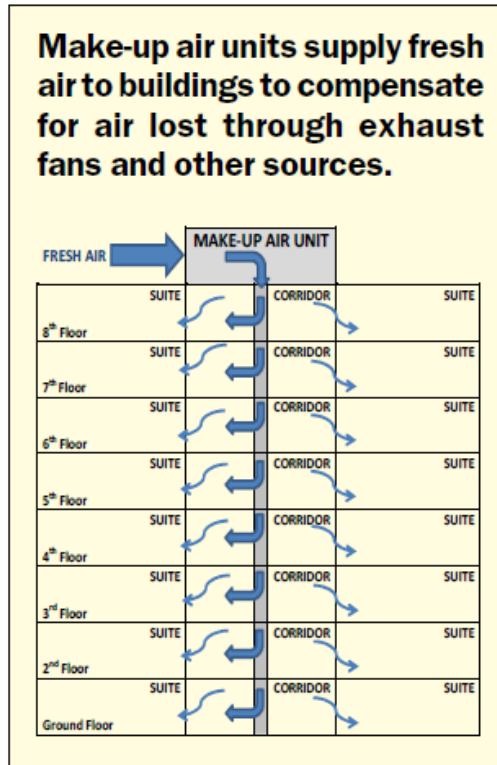
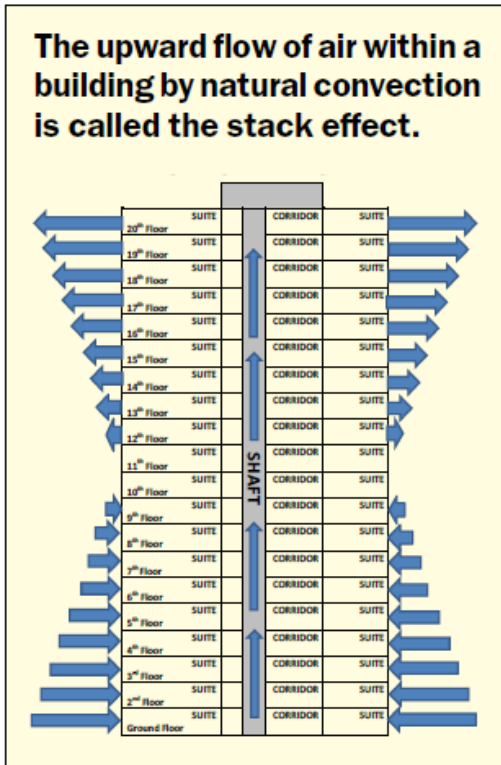

At the Discovery Building, the existing MAU also provides space heating to corridors 24/7, in the form of heated air to around 19°C (66.2°F). The efficiency of the equipment's gas fired section is typically around 80%. In the suites, electric baseboards are installed for space heating and residents are able to control the temperature in their units via a thermostat. Domestic hot water production is decentralized via electric hot water tanks that are installed in all suites.

Schematic diagram of air flow in a high rise multi-unit residential building.

Proposed Solution

In order to replace the building's existing MAU and achieve gas savings at the same time, the proposed solution is to implement an innovative technology that consists of two heating sources:

- 1) A gas fired section that only comes on when the outdoor air temperature is at or below 1°C (33.8°F).
- 2) An electrically driven air source heat pump (ASHP) that heats the ventilation air when the outdoor temperature is greater than 1°C. At warm outside temperatures, the ASHP can be reversed and the device can be used to supply cold air to the corridors which can be a significant benefit in the summer.

This hybrid MAU is manufactured by Trane, a global heating, ventilation and air conditioning company. The Horizon outdoor air unit product family consists of many different model options and can provide functions such as ventilation with filtration, cooling, dehumidification, and heating. The specific Horizon N360 OAN model that has been proposed for the Discovery Building, is already in use at two residences in Victoria, BC. One was installed in 2014 and the other in 2015 and both devices have been operating successfully since then.

In terms of the velocity of the air flow into the building, the Horizon N360 OAN model reaches 10,000 cfm. CFM is an acronym for cubic feet per minute - the measure of air volume moved by the fan blower. It is important to choose a fan with a cfm rating appropriate for the building size to ensure adequate ventilation. A general rule is to require 50 cfm/suite. The N360 OAN is therefore suitable for a multi unit residential building with up to 200 units. Smaller equipment sizes are, of course, also available.

Proposed Project Details

System Design

Technology	Hybrid Make Up Air Unit/ASHP System
Make & Model	Trane Horizon N360 OAN
Service provided	Heated ventilation air for corridors
Gas fired section	≤ 1°C = 6.5% of the year
Electrical heat pump section	>1°C – 18°C
Electrical heat pump cooling section	>18°C
Coefficient of performance (COP)	3.8
Cubic feet per minute (cfm)	10,000
Status	Project declined

The proposed retrofit consists of replacing the entire existing gas fired MAU with a new ASHP gas fired hybrid unit. Thanks to records of weather data and heating degree days, it is possible to calculate precisely the average number of annual hours at each temperature. In Vancouver, the average outdoor air temperature throughout the year is 10°C (50°F). The hybrid unit uses a gas fired coil at a temperature of or below 1°C (33.8°F) which equates to approximately 570 hours per year, or 6.5% of the year. Above 1°C and up to about 15°C – 18°C (depending on the setting), the ASHP comes on to heat the ventilation air. This means that for the vast majority of the heating season, electricity, instead of gas, is used to condition the incoming air. What is more, the heat pump cycle can also be reversed and switched into cooling mode. The added benefit of this technology is thus that in the summer months, it can also provide cooling to the corridors.

Heat pumps (HPs) provide one of the most energy efficient forms of heating (and cooling) because they extract more energy from the air (in the form of heat) than they consume (in the form of electricity). This means that most of the energy for heating comes from the external environment (the air); only a fraction comes from

electricity. HPs move heat instead of generating heat by circulating a substance called a refrigerant through a cycle of evaporation and condensation.

A HP's efficiency is measured by the coefficient of performance (COP). The Horizon N360's COP is 3.8 meaning that for every 1 kW of electricity used by the HP, 3.8 units of energy is transferred to the incoming air. Compared to a conventional gas fired MAU, the hybrid MAU uses about one third of energy for the same service. Another advantage this equipment offers is that the retrofit is not disruptive for the residents. It can easily be installed on the rooftop without impacting the occupants.

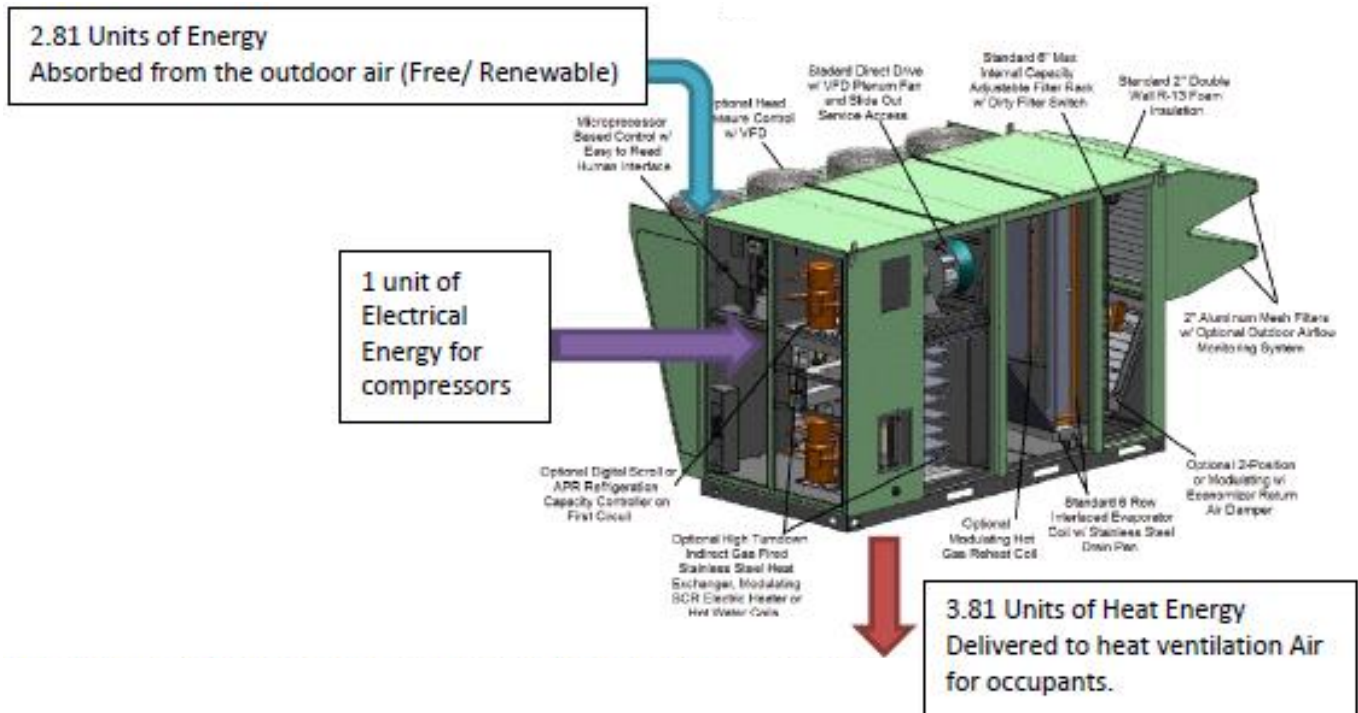

Cross-section of the Trane Horizon N360 unit.

Estimated Costs

Equipment cost	\$87,000
Electrical upgrade cost	\$10,000 min.
Installation cost (pad and ducting)	\$5,000 (modifications to existing pad and ducting)
Installation cost (louvers)	\$10,000
Less replacing conventional unit	- \$35,000
Total incremental cost for installation	\$77,000
Annual maintenance cost	\$1,000
Annual energy savings	541,320 kWh/year = 79.8% for make-up air
Annual energy cost savings (incl. carbon tax)	\$7,798
Annual GHG reductions	118.6 tons CO ₂ e = 97% for make-up air
Payback	10 years

The equipment cost of the Trane Horizon N360 unit is approximately \$87,000. The estimated installation costs amount to about \$5,000 which includes modifications to existing pads and ducting. The primary concern in a retrofit application of this type of equipment is the available electrical capacity to accommodate the additional load. For the 10,000 cfm MAU the ASHP requires 66 amps. Especially in older buildings, the amperage of the electrical panel might need to be increased to accommodate the additional load of a heat pump. At a high-rise residential building, costs for such upgrades are estimated to be at least \$10,000.

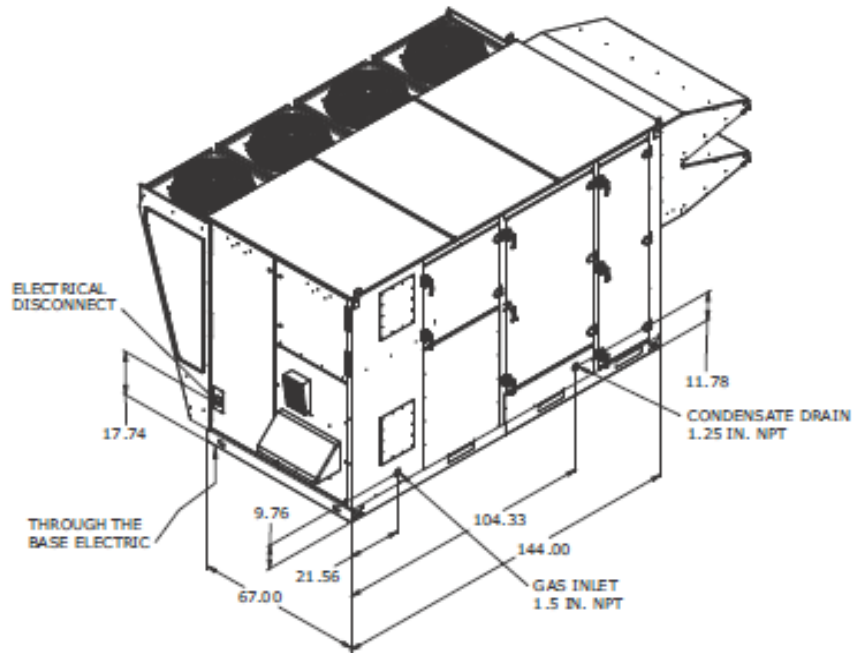

Trane Horizon 360 OAN unit utility connections.

When the Discovery Building was examined in greater detail for the pilot project, it was uncovered that the building's rooftop enclosure is a barrier for the heat pump. ASHPs require outside air to operate.

With the rooftop enclosure additional louvers would be required to bring in and discharge the air from the heat pump system. This would add another \$10,000 to the installation. Since the existing MAU is at the end of its lifetime, replacing it with a conventional unit would cost about \$35,000. These replacement costs can therefore be deducted when calculating the retrofit project's business case.



The Admiralty (front) and the Discovery Building (back) from False Creek.

The total incremental cost for this new hybrid MAU installation would therefore amount to approximately \$77,000. The expected lifetime for this type of equipment is about 20 - 25 years. Annual maintenance is very important for the proper functioning of a heat pump. Maintenance costs would probably rise to about \$1,000 per year.

Estimated Energy Savings

The hybrid MAU is estimated to save about 541,320 kWh of energy per year (0.54 GWh/year) for a high-rise multi-unit residential building in the Lower Mainland with about 200 suites. This represents an almost 80% reduction in gas consumption for make-up air which is made possible by the electrically driven heat pump and the gas coil that would only come on for a fraction of the heating season when temperatures are very low.

These energy savings translate into annual energy cost savings of about \$7,800 including the avoided carbon tax that is levied on fossil fuel energy in BC. The GHG emission reductions that would result from this natural gas cutback are estimated to be 118.6 tons of CO₂e, representing a more than 90% emission

reduction compared to a conventional MAU. If the retrofit project at the Discover Building was implemented today, the payback would be just under 10 years.

Barrier

The Discovery Building faces a unique barrier to the proposed retrofit due to the rooftop's physical enclosure. Since ASHPs require sufficient air to operate, additional louvers would be required to bring in and discharge air from the heat pump system. This complication adds cost to the proposed retrofit and makes the condo tower unattractive as a pilot project for this new technology. At the time of writing, the Strata Council had not made a decision yet on how to move forward and how to replace the existing MAU.

Consultant Feedback

The engineering consultant who worked on the energy study for the pilot project explains: *"The equipment has been on the local market for about five years. It has been installed in a few buildings in Victoria where it works well."*

He believes that in Vancouver the industry has so far overlooked this innovative product. *"Make-up air units are often overlooked in mechanical design in buildings because designers don't realize how much energy they consume all year round. There needs to be greater awareness. There might also be apprehension to try a new product."*

The consultant explains that the advantages the equipment offers are substantial: *"Every building, no matter if it is a low-rise or high-rise multi unit residential building, has a make up air unit and more than 90% are run by natural gas. The potential for replacement and GHG savings is substantial".*

In terms of energy savings, the consultant reports that the hybrid MAU offers the benefit of being able to calculate and predict with a high degree of certainty the energy savings and payback period that will result from the installation. *"It is easy to calculate how much energy a make-up air unit uses because we know the average hourly outside air temperature for the year. We also know what temperature we are heating the air to, that there is a constant volume of air, and how efficient the unit is. All of these variables are in a linear relationship to each other. The energy savings are thus in the hands of the building operator who manages the equipment's operation and occupant behaviour will not influence the unit's performance."*

On top of that, the ASHP provides another advantage: *"It offers cooling in the summer. For buildings in Vancouver that currently don't have cooling this hybrid unit can at least cool the corridors. This could offer social spaces to residences and potentially also a cooling influence in the suites that would be particularly welcome in units that suffer from overheating in the summer."* He adds further: *"In the Lower Mainland we are in cooling mode typically from June to September. Additional cooling is particularly appreciated in towers that are glass heavy and experience a lot of solar gains, internal heat gains, and density."*

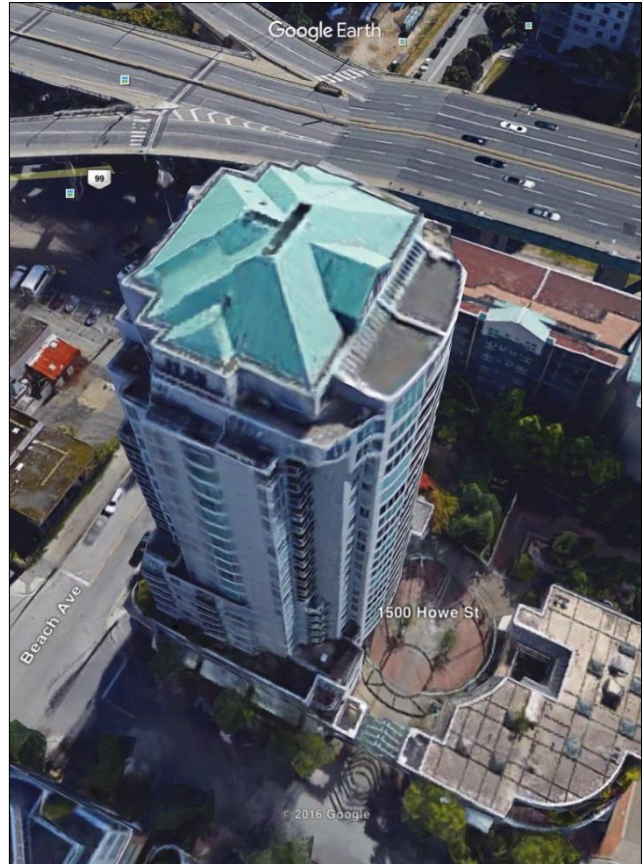

Bird's eye view of the Discovery Building showing the rooftop enclosure.

Further investigation and pilot projects are required to determine potential barriers and solutions for a wider adoption of the technology. The consultant summarizes: *“The primary concern is the electrical capacity at the roof to accommodate the heat pump itself. It can be costly to run new electrical lines from the main electrical panel, which is often in the basement, to the rooftop. We need to determine whether insufficient electrical capacity is frequently an issue and find out exactly what the costs of upgrades would be.”*

Applicability

The hybrid MAU is a very energy efficient alternative to traditional gas fired MAUs and promises to save money, natural gas, and reduce GHG emissions. Thanks to the different model options and sizes, the outdoor air units can be widely applied to multi-unit residential buildings in the Lower Mainland. Attention should be paid in the selection process to choose a fan with a CFM rating appropriate for the building size to ensure adequate ventilation. The retrofit installation is thought to be relatively easy and non-intrusive for residents.

The buildings targeted first should be those that are scheduling to replace their existing MAU so that only the incremental costs of replacement need to be considered for the business case, as well as potential additional costs for electrical upgrades.

While it is true that the heat pump’s COP decreases as temperatures decline, because it is more difficult to extract heat from cooler air, the combination with the gas fired section makes the equipment also applicable for use in colder climates. Given the local mild climate, the Lower Mainland is an ideal geographic area for the technology’s application.

The hybrid MAU is a very promising technology and retrofit solution. Further examination and pilot projects are necessary to enhance industry familiarity with the product and collect more data on multi unit residential buildings’ electrical capacities and costs of potentially required upgrades.

Limitations

This type of equipment has a number of limitations that need to be considered depending on site and building specificities:

- Sufficient free rooftop space is necessary. In particular, ASHPs require outside air to operate and should not be completely enclosed. For buildings with rooftop enclosures, application may still be possible but only if additional louvers are added which increases the retrofit costs.
- The colder it gets outside the less efficient the ASHP will be. This is why the heat pump is coupled with a gas fired coil to provide sufficient hot air during the coldest months of the year.
- Existing buildings often have insufficient electrical capacity for heat pumps which means that upgrades can be required for their application. This will increase the installation costs.
- Since the technology is relatively new in the Lower Mainland and exists of two distinct sections, the equipment capital costs are higher than conventional MAUs. To mitigate this, hybrid MAU retrofits should be planned when the existing ventilation equipment has reached the end of its lifetime and needs replacement, so that only incremental costs need to be taken into consideration.
- All ASHPs make noise when they operate which stems particularly from the fan. Since hybrid MAUs are generally placed on rooftops that are otherwise not used, the generated noise should not be an issue.

Case Study 5

The Meridian Cove – Vancouver

Decentralized, through-wall Air Conditioner & Heat Pump with integrated fan coil

Building Description

Address	2201 Pine Street, Vancouver
Ownership	Condo, Strata Council
Type of Building	Mid-rise multi-unit residential
Year of Construction	1991
Number of units	125

Constructed in 1991, the Meridian Cove is an 11 storey, 125 unit, concrete frame residential building in Vancouver's Fairview neighbourhood. It is a luxurious condo with a faceted, brick veneer facade with bay windows and a terraced roof plan. The building has electric baseboard heating but no air conditioning.



East side of the Meridian Cove

Challenge

Like many condos, the south and west facing units in particular require cooling during the summer; by contrast, the north and east facing units are hard to keep warm in the winter. The Meridian Cove's window frames are badly insulated which encourages air leakage and the development of interior winter window condensation. Window condensation is a common problem that can ruin window-frame finishes, lead to mould growth on windowsills, and low indoor air-quality.

In the fall of 2015, a few Meridian Cove unit owners, who suffered from excess heat, discussed examining the technological evolution of air conditioning units for potential implementation in their suites. Conventional air conditioning units have been unpopular among condos due to lacking outdoor space, noise from the outdoor compressor, and their outside appearance. At the Home Show in the spring 2016, one of the residents came across a new, innovative product that had the potential to provide both cooling and heating needs.

Solution

The Innova 2.0 is a combined air conditioning and heat pump unit that can cool rooms in the summer, heat them in the winter, and dehumidify all year round. It is a unique through the wall product that functions



Innova 2.0 unit installed on an exterior wall at a Meridian Cove condo unit.

Outside duct holes with vent covers and a small drain pipe on the balcony of the condo unit (vent covers not yet painted).

without the need of an outdoor compressor unit, thereby saving money on installation costs. Mounted on an exterior wall, the Innova 2.0 simply requires two duct holes of 162 mm each (6.4 in). To minimize their aesthetic appearance, the duct holes are disguised with vent covers that are available in many different styles and colours to fit the building exterior.



Innova 2.0 unit installed in a condo unit at the Meridian Cove.

Strata Decision Process

The unit owner took the product information back to the Strata Council which consequently organised two informational meetings with the Innova supplier. During the meetings, interested owners received equipment demonstrations to check their cooling effectiveness and operating noise.

During the summer 2016, a few more meetings were held to determine how many unit owners were interested, and discuss installation considerations. The costs and benefits of the Innova product were compared to traditional ductless minisplit air conditioning units.

The Strata Council's biggest concerns were how the appearance of the building would be altered, how to ensure consistent placement and appearance of the duct holes, and how to minimise potential noise impacts on neighbouring units. Instead of mandating unit owners which brands or technologies they had to choose, the Council developed a set of rules that unit owners now have to comply with should they wish to install air conditioning or additional heating:

- Each installation has to be approved by the Council prior to making any modifications; the approval process verifies the choice and placement of the equipment.
- Installations have to be carried out by qualified installers (electricians).
- Proposed equipment is not allowed to significantly affect the exterior of the building and has to stay below specified noise levels.
- Two types of technologies were pre-approved by Council that meet all the specified criteria (Innova 2.0 and ductless minisplits). To avoid reviewing each technology on a case by case basis and expedite the approval process, unit owners can choose from these two technologies.
- The unit owner has the ultimate responsibility to ensure the equipment is correctly installed and take care of potential repairs should there be any damage.

In addition, minor modifications to the Strata bylaws were required. These changes consisted of deleting a bylaw section that stated that no air conditioning units could be retrofitted. Instead, it was specified that installation of air conditioning, or similar apparatus designed to improve the air flow cooling and heating was possible but prior approval by the Strata Council was required. Describing the process to be followed was easier

than specifying the technical requirements. All in all, the consultation and approval process took six months and the bylaw changes were ratified at the Annual General Meeting in September 2016.

Project Details

Technology	Heat Pump & Air Conditioner
Make & Models	Innova 2.0 with integrated fancoil Innova 2.0 Elec with integrated electrical heater Innova 3.0 with condensate vaporizer
Year of Completion	Dec 2016
Equipment Cost	\$ 3,200 - \$ 3,500
Installation Cost	\$ 500-\$ 1,000
Annual Maintenance Cost	\$ 80
Voltage (V)	110 or 220
Maximum Noise (dB)	27
Energy savings (kWh) Q1/2017	609
GHG (kg CO2e) Q1/2017	6.7

Product Options

Innova 2.0 comes in two different sizes and voltage options: (1) 9,000 BTU for smaller rooms below 700 sq ft; (2) 12,000 BTU for rooms about 700 sq ft. Both sizes are available in 110 or 220 voltage. All 2.0 units are manufactured as heat pump units which includes a drain pipe for condensation. Draining the condensate expelled by heat pumps can sometimes be a problem, particularly in retrofit applications. There are therefore two options, should drainage not be available:

1/ The heat pump function can be deactivated through the control. In this case, the unit will act as a cooling device only; it can still provide heating in the winter through the fan coil, albeit with less efficiency and providing lower energy savings.

2/ The better solution is to add a condensate vaporizer, “3.0”, to the standard model. In this case, water condensation is brought into the unit and atomized by a system using piezoelectric cells. It is then sprayed out through the exhaust air hole of the unit by a microfan. Such fitting can only be done at the factory and needs to be pre-ordered. The additional 3.0 condensate nebulizer is installed within the unit and requires no additional hole in the wall.

Another product option is the 2.0 Elec that includes an integrated electrical heater for colder climates or in applications where the floor area exceeds 700 sq ft. In this version, the heat pump is integrated with a 1 kW electric resistance heater that intervenes automatically when outdoor temperatures are low (up to -7 °C).

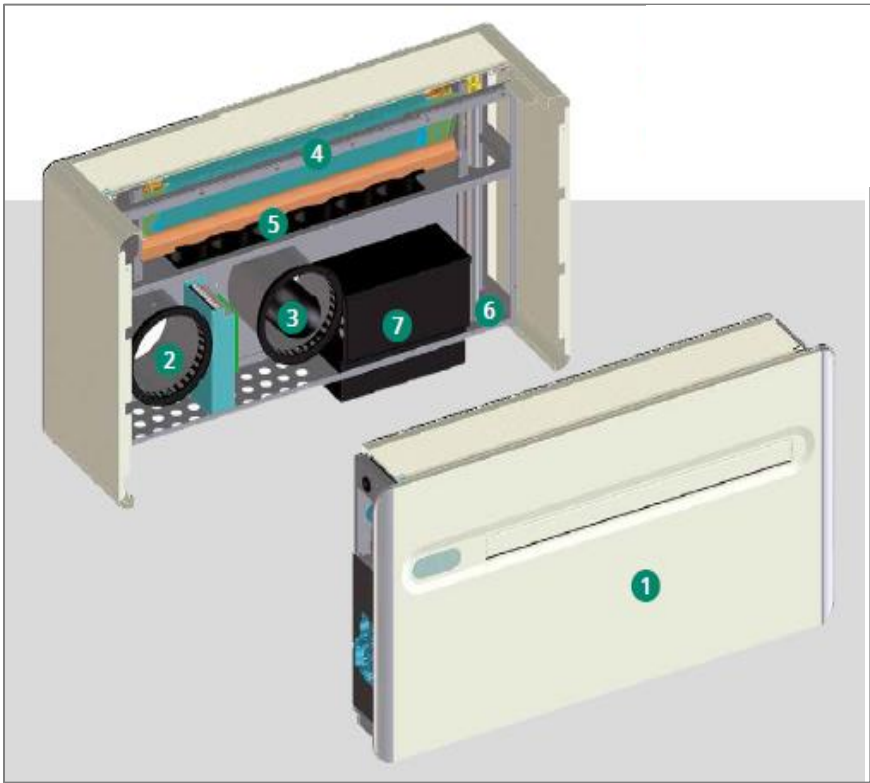

- 1...Innova 2.0 unit
- 2...Air inlet extension 2.0
- 3...Air outlet extension 2.0
- 4...Heating water coil
- 5...Heating fan
- 6...Hydraulic connections
- 7...Condensate vaporizer 3.0

Innova 2.0 cross section diagram.

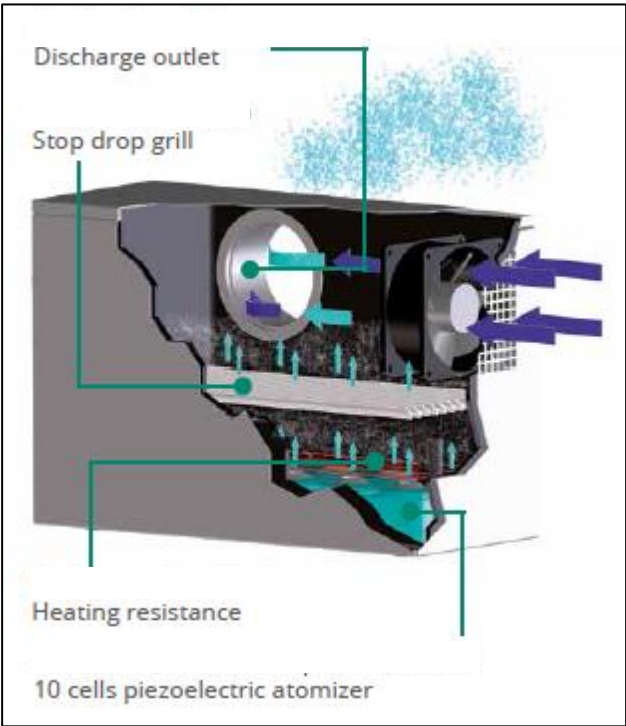

3.0 Condensate vaporizer.

3.0 Condensate vaporizer cross section diagram.

Electrical Installation

There are two installation options available to connect the unit to the electrical supply:

1/ The appliance is equipped with a power cord and plug that are fully compatible with standard electrical supplies in buildings (applicable to all product options). All that needs to be done is inserting the plug into a nearby socket.

2/ To avoid an external power cord, it is possible to connect the appliance through an existing or new electrical cable inside the wall (recommended for installations in the upper part of the wall).

The average electricity consumption of the Innova 2.0 in heating mode is 720 Watt and 730 Watt in cooling mode which is roughly equivalent to a small microwave oven. The addition of electric resistance in the Innova 2.0 Elec model does not add any electrical consumption. The table below provides a comparative view of approximately how much electricity the Innova units and common household appliances use.

Electrical Appliance Usage Chart		
Appliance	Approximate Wattage	
Innova 2.0 unit sizes	9,000 BTU	12,000 BTU
Innova 2.0 in heating mode	638	720
Innova 2.0 in cooling mode	630	730
Electrical Heater (portable)	1500	
Ceiling Fan	60	
Air Conditioner (portable)	1050-1300	
Clothes Washer	500	
Microwave Oven	600-1000	
Hair Dryer (portable)	1000-1800	
Kettle	1200-1500	

Source Appliance Wattage: Toronto Hydro Appliance Usage Chart, 2017

Costs

Equipment costs are about \$3,200 to 3,500/unit, depending on the size, with an additional \$500-\$1,000 for the installation. Adding the electric resistance heater in the 2.0 Elec model increases the equipment cost by about \$500. In terms of maintenance requirements, users are supposed to wash the air filters on a monthly basis. Chemical cleaning by a professional should be conducted annually at a cost of about \$80.

At the Meridian Cove, condo owners were able to negotiate a discount on the normal equipment price. Residents chose different equipment options: (1) heat pump mode with outside drainage, (2) cooling mode with fancoil only, (3) heat pump with condensate vaporizer. Installations took place in the fall 2016. Out of about 35 interested unit owners, 25 have so far installed the product. Due to the brick walls and the different levels and access to the building, a swing stage was required. This made the installations weather dependent and slightly more complex than at other condos. In some cases, the Innova product replaced electric baseboards, in others they were left in place. No suite required an electrical upgrade; connections from previous baseboards or existing electrical outlets in the walls could be used.

Energy Savings

It is still early to draw conclusions on energy savings that result from the installations at the Meridian Cove since they were only completed six months ago. One of the north facing unit owners, however, who used the

equipment in the heat pump mode all winter, achieved energy savings of 609 kWh in the first quarter of 2017 compared to 2016, despite the cold winter. This resulted in greenhouse gas savings of 6.7 kg of CO₂e and a reduced electricity bill of \$53 for the same period. In this particular suite, the standard Innova 2.0 unit is installed in a large open space (combining living room, kitchen, and hallway); the appliance is therefore heating a larger floor area than it is designed for. Energy savings would likely be higher in an appropriately sized room. Historically, condo owners requiring summer cooling have been using fans and portable air conditioners. The Innova unit therefore does not introduce a new summer cooling load but rather provides a more energy efficient way to chill the suites.

Overall, energy savings were not the primary motivation of the condo owners for the installations of the HRVs but rather improving the comfort of the suites and reducing window condensation. Energy savings will be highest when the appliance is adequately chosen for the room size and in suites that use the appliance in heat pump mode during winter times, thereby reducing the need of electric resistance heating. In suites that did not use air conditioning devices prior to the installation, annual energy savings will likely be diminished by additional cooling loads in the summer.

User Experience & Recommendations

“I would recommend the technology to others if they need cooling in their apartments or better heating. The Innova equipment is certainly worth it. It is quiet and you can run it in cooling mode only, without using the compressor. Removing excess humidity from the air is another big advantage. There are few other options available that are so efficient and that look good,” explains one of the Meridian Cove residents.

So far, the owners have been satisfied with the performance of the equipment and report that the noise level is minimal. In large open spaces a second unit on the opposite side of the room could be beneficial since one unit might not be enough to keep large spaces warm in the winter. Moreover, the small outside drain pipe can freeze should temperatures drop in the winter. The solution is to wrap foam or heat tape around the pipe.

Meridian Cove residents have another piece of advice for other interested condo owners: *“Find the engineers in your building and the people who are interested to form a small committee of leaders who will drive the project forward. Strata Council members will likely not have technical knowledge, so identifying individuals with expertise who act as liaison and advisors is very helpful. Otherwise, it is easy for the Council to get bogged down in daily issues.”*

Applicability

This combined heat pump and air conditioning unit can be widely applied to multi-unit residential buildings, townhouses, single family homes, and hotels. Many condos and apartment buildings in the Lower Mainland suffer from excess heat in the summer and rising heating demands in the winter due to poor windows and insulation. The Innova 2.0 and similar technologies could provide viable retrofit solutions to alleviate these challenges. The space heating savings will have greater greenhouse gas reduction for buildings with gas heating systems.

Limitations

This type of equipment has a number of limitations that might come into play depending on building specificities:

- Sufficient exterior wall space is required which can sometimes be difficult in retrofit applications. In particular, condos with full floor to ceiling windows and balconies might have limited available exterior wall space.
- For the Innova 2.0 to function in heat pump mode a drain is required for condensation. Suites that don't have an existing nearby drain or that don't have a balcony or deck with a drain can add a condensate vaporizer to the standard model.

- Additional electrical lines to the equipment might have to be installed which would add cost to the installation.
- In buildings that previously had no cooling and where units did not already use less efficient cooling methods, energy savings may be diminished by the introduction of additional summer cooling loads.
- While the Innova 2.0 provides a cost efficient technology that is generally cheaper than comparable products, affording the installation may not be financially feasible for all condo unit owners and landlords.

Case Study 6

Concorde Place – Burnaby

Decentralized Ventilation System with built-in Heat Recovery Core

Building Description

Address	9521 Cardston Court, Burnaby
Ownership	Condo, Strata Council
Type of Building	Townhouse rows
Year of Construction	1983
Number of units	25

Constructed in 1983, Concorde Place is a 3 storey, 25 unit, concrete townhouse complex in Burnaby's Lougheed Town Centre area. It provides more affordable, spacious condos with a terraced roof plan. The townhouses have electric baseboard heating, gas fired boilers for domestic hot water, and no air conditioning. A high-rise residential tower, situated directly behind the townhouses, is also part of the same Strata organisation.



Front side of Concorde Place townhouse complex.

Challenge

Four years ago, the deterioration of the building condition became apparent as parts of concrete fell off the walls and moisture and mould issues on walls and windows were common. This prompted a first assessment report analyzing the state of the building and identifying required upgrades. The townhouses suffered from poor air quality, air leakage and from condensation problems on exterior walls and on window frames. The building has no make-up air system for the corridors but only small, inline fans on exterior doors that draw outside air into the corridors. Air then travels into the suites via intentional gaps under the entrance doors. This insufficient ventilation system left many suites under-ventilated and provoked moisture issues. Matters were made worse by certain residents covering the gaps under the doors to avoid cold air coming into their suite. Due to the townhouses' poor condition, their real estate values dropped and owners realized that retrofits were necessary. First, to improve the quality and comfort of their homes; Second, to enhance the value of their properties.

Solution

A two-year consultation process involving several engineering companies, the Strata Council and all unit owners followed. At the end, it was decided that a large-scale retrofit, consisting of multiple measures, would be the best solution to improve the building condition and property value:

- Exterior wall insulation was installed at the townhouses and rain screens were upgraded (improving insulation values from R2 to R17).
- Modern stucco was applied as an exterior wall finish and the townhouses were repainted.
- Parts of the high-rise tower's wall insulation were also upgraded, including rains screens and new flashing details.
- All townhouse windows were replaced with double glazing, including some triple glazing windows in duplexes.

- As a result of the insulation and window upgrades, the townhouse suites had become more airtight. Improving the ventilation in the suites was therefore crucial to enhance air circulation and reduce humidity. A product from Germany, combining in-suite heat recovery ventilation (HRV) and air exchanger, represented the best value for money: Two Lunos e² were installed in two different rooms of each townhouse suite.

Lunos e² are a decentralized ventilation system with a built in heat recovery core. The basic unit is a through wall fan, with a ceramic regenerative heat exchanger behind it. Operating and wired in pairs, these fans provide continuous ventilation without the need for duct-work; they are installed directly in the exterior wall. The fan's heat recovery is possible thanks to a ceramic core that is charged in a 70 second cycle for a standard fan (250 mm = 9.8 inches). After 70 seconds the fan reverses and the incoming air absorbs the stored heat on its way in. To minimize the equipment's aesthetic appearance and protect it from rain and dust, the fan holes are covered by wall caps that are available in different colours to fit the building exterior.

Diagram of Concorde Place townhouses indicating the locations of Lunos HRVs.



Strata Decision Process

After the first building assessment report was received three years ago, a special building envelope committee was formed to advise the Strata Council and all owners on the suggested building upgrades. Since the Strata is made up of the townhouse rows and the high-rise apartment tower, all 211 unit owners had to be involved in the decision process.

The building envelope committee consisted of two Strata councillors and regular condo owners; it was open to anyone who wanted to participate and the number of members varied between 7 to 12 people throughout the process. Fortunately, one person on this special sub-committee was a construction industry professional and was able to provide an insider view on how to tackle the project. A total of four engineering companies were approached and the Strata received three retrofit proposals. They all concluded the same assessment of the building condition and recommended the same upgrades.

The building envelope committee played a special role in liaising between engineering and construction companies, the Strata Council and unit owners. During the two-year consultation process a lot of communication was required between the different stakeholders. The decision was made to select the company that had prepared the first building assessment report to carry out the retrofit and construction management work. It was challenging to get all 211 unit owners to agree on such a major investment decision but the communication strategy and transparency of the decision process paid off: 83% of unit owners agreed on the proposed retrofits at the first vote. The upgrades did not require any Strata bylaw changes.

Project Details

Technology	Decentralized Heat Recovery Ventilator (HRV)
Make & Model	Lunos e ²
Year of Completion	Feb 2017
Equipment Cost	\$1,000/pair
Installation Cost	\$2,000-\$3,000/pair
Maintenance Cost	Not applicable
Heat Recovery Efficiency	90.6%
Humidity Recovery	20-30%
Power Draw	1.4 W @ 15m ³ /h 2.8 W @ 30m ³ /h
Noise Level (dB)	26 max.

Product Options

The Lunos e2 is designed for living- and bedrooms and is available in two sizes for different wall thicknesses:

- 1) e2 standard: minimum wall thickness 12 in (300 mm);
- 2) e2 short: minimum wall thickness 7.5 in (190 mm); However, the short version comes with a slightly lower efficiency (~85%).

The devices can only function in pairs operating in opposite direction. Each fan operates 70 seconds (50 seconds for e2 short) in supply air operation, the other 70 seconds (50 seconds for e2 short) in exhaust air operation. After this, the air flow directions are changed. This push pull operation assures that the total supplied ventilation volume is equal to the total exhausted volume. If a pair of fans is installed in two different rooms of a dwelling, such as at Concorde Place, a sufficient under cut in the doors is required to allow unrestricted air movement between these spaces.

The Lunos e2 have high and low settings that regulate the air volume and ventilation rate. Noise levels reach a maximum of 26 dB at the highest setting. While this is a low noise level for this type of technology, it should be considered that the frequent oscillating of the devices can be noticeable due to the fan coming on and off every 50 - 70 seconds.

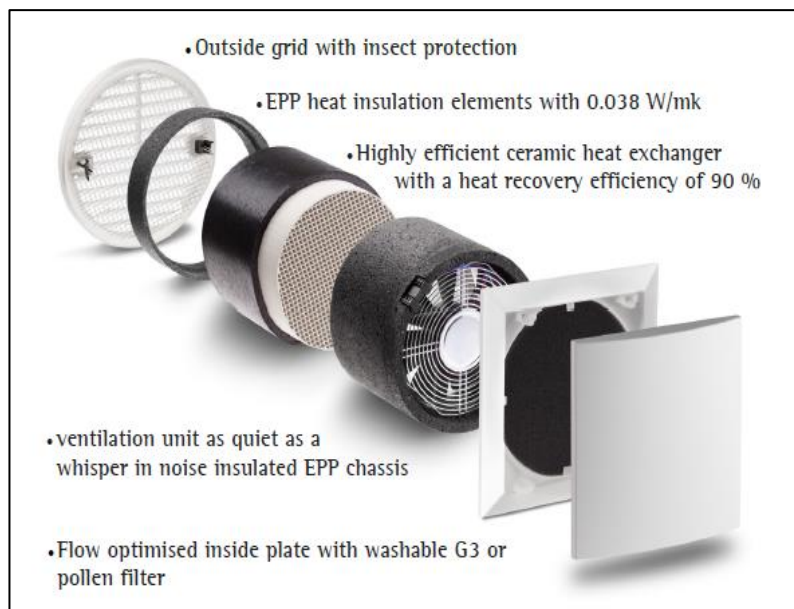

The manufacturer recently launched a new model suited for large rooms that can also be used in kindergartens, schools, offices, hotels and medical practices. In addition, special models are available for functional areas such as bathrooms, washrooms, and kitchens.

Lunos e2 cross section diagram.

Electrical Installation

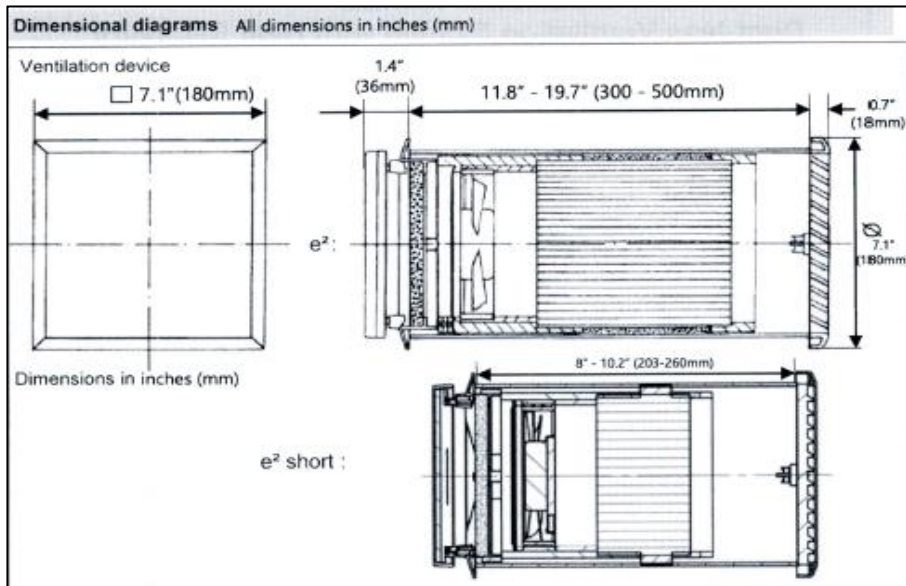

The system is powered by electricity through an existing or new electrical cable inside the wall. It includes one transformer (110V-12V) with wiring running to each fan. Both devices are regulated by a universal controller (user switch). A total of four fans (two pairs) can be wired to one controller. In retrofit applications, upgrading the electrical panel is unlikely to be necessary.

Lunos e2 and e2 short dimensional diagrams.

At Concorde Place construction work started in the summer of 2016. The Lunos equipment installations took place in February 2017. A pair of HRV units was installed on exterior walls, below windows, in two different rooms of the 25 townhouse suites. Electrical panels didn't have to be upgraded since wires could be pulled off the plugs that were available.



Pictures of the same Lunos e2 unit installed at a Concorde Place townhouse unit (from left to right):

- 1/ Inside, e2 without cover; double switch to the right.
- 2/ Inside, e2 with cover.
- 3/ Outside, e2 with wall caps.

Costs

The Lunos e2 equipment costs about \$1,000/pair. Installation costs vary by building depending on required electrical and insulation work. At Concorde Place, installation costs amounted to \$2,000-\$3,000 per suite which included cost for the insulation around the devices. Maintenance needs are minimal since there is only one moving part—the fan unit. There is no cost associated with maintenance since it can be carried out by the owners themselves. An LED light will come on when the filter requires servicing. Cleaning consists of taking off the indoor closure, removing the filter and inserting a new or cleaned filter (the filter can be cleaned by a dishwasher).

The total refurbishment costs at Concorde Place were budgeted at \$7.5 m for both the townhouses and high-rise tower. Out of this total project cost, the cost for the HRV installations in all townhouses accounted for approximately \$90K which is a small portion out of the total refurbishment cost.

The work is currently being completed and final costs will likely be slightly lower due to savings that could be made along the way. The entire funding for the refurbishment came from the owner group through a special assessment that was levied on all units. Each unit owner's financial contribution was calculated based on the allotment size (floor area).

Energy Savings

The German manufacturer advertises the energy efficiency of the appliance: The power requirement per device varies according to the ventilation setting: 1.4 W at 15m³/h of delivered volume and 2.8 W at 30m³/h of delivered volume. This results in a fan power of 0.09 W/m³ and a heat recovery efficiency of 85% - 90%.

It is important to note that in a retrofit project such as this one, the Lunos units are not energy savings devices on their own. Their primary purpose is to provide fresh air, where there previously wasn't any, in a manner that avoids the heat loss associated with keeping windows open.

At Concorde Place energy savings were not the primary motivation for the large scale renovation but rather improving the building condition, comfort, and the indoor air quality. As a consequence, no formal energy audit was completed. At the time of writing it was too early to draw conclusions on energy savings that result from the retrofit and energy efficiency upgrades since work is still ongoing and a full annual heating cycle has not been completed.

Townhouse residents reported that their electric heating bills were considerably higher during the cold winter of 2016/17. This is because, as part of the retrofit process, the walls had been stripped of insulation but the new external wall insulation had not been installed yet. These one-off, steep electricity costs were an additional short-term monetary challenge for residents. In the long-run, Concorde Place residents should see a significant decrease in their energy use due to the considerable improvement in wall insulation and the window upgrades. These energy savings will be enabled by the HRVs. The building upgrades have also improved Concorde Place's real estate value and extended the building lifetime.

User Experience & Recommendations

The manager of the engineering company explains: *“Because the townhouses were made more airtight through the improved insulation and windows, we had to find a solution to enhance the ventilation. The problem was the exhaust. How would the air leave the suite?” “It took a few months of research to find this product and when we did, we knew it was the solution: Combining the HRV and air exchanger.”* He adds: *“For future projects, it would be ideal to install four devices per suite. This was not possible at Concorde Place since the ventilation budget per townhouse was limited.”*

So far, the townhouse owners have been satisfied with the performance of the Lunos e2 HRV equipment with the exception of the constant audible on-off cycling of the units. The oscillating and reversing of the fan has been an issue for some, particularly where the equipment was installed in bedrooms. Lunos units are manually

controllable from low, medium to high airflow. *“At the lower settings the equipment is fairly inaudible, which is good, but at the highest setting the noise is noticeable and residents have talked out it”*, explains one of the Council members. *“The problem is that at the lower settings you are not really circulating enough air through the suites, so we recommend leaving the HRVs on the highest setting most of the time, particularly if people are not frequently opening their windows.”*

One of the consequences will likely be that some residents turn off the HRVs because of the noise. To prevent this, the engineering company and the Strata Council recently sent out user instructions to all unit owners including explanations of why the Lunos e2 equipment needs to keep running. *“We also advised residents that they can open the windows as viable ways to ventilate their suites. As unit owners change over time, this message will have to be repeated because otherwise moisture issues might occur again,”* adds a Council member.

The Concorde Place Strata Council has some useful feedback for other condos that consider upgrades. *“The most important aspect of making the project work is communication. In addition, a leading group of owners is required that drives the project forward”*. The Council member explains further: *“It is good if there are conflicting and dissenting opinions among that group and people with different expertise so that you have good conversations and you scrutinize the different proposals. Invite all unit owners to be part of the process and consultation group; it allows for more inclusion.”*

Applicability

This decentralized ventilation system with a heat recovery core can be widely applied to multi-unit residential buildings, townhouses, and single family homes. Many condos and apartment buildings suffer from poor indoor air quality due to inadequate ventilation. Corridor pressurization does often not provide intended ventilation rates to a large number of suites. There is often significant leakage along the ventilation air flow path from the duct and the corridor. It is therefore a good solution to make exterior enclosures more airtight while supplying ventilation air directly to suites and limiting the loss along the flow path. The Lunos e2 and similar technologies could provide viable retrofit solutions to alleviate these challenges. The space heating energy savings will have greater greenhouse gas reduction for buildings with gas heating systems.

Limitations

This type of equipment has a number of limitations that need to be considered depending on building specificities:

- Sufficient exterior wall space is required which can sometimes be difficult in retrofit applications. In particular, condos with full floor to ceiling windows and balconies might have limited available exterior wall space. The units also require air access so no curtains or similar items should cover them.
- Additional low voltage electrical lines to the devices might have to be installed which would add cost to the installation.
- While noise levels are low and the equipment contains highly efficient motors and balanced fans, the oscillating of the fan in particular can be noticeable. If there is no noise to start with, any additional noise will be perceptible. There is a risk that sensitive residents will consequently turn the equipment down or completely off.
- While the Lunos e2 provides a cost efficient technology that is generally cheaper than comparable products, the installation costs can be higher due to insulation requirements. Affording such an appliance retrofit may not be financially feasible for all condo unit owners and landlords.

12. Conclusions

MURBs represent a large proportion of Vancouver's housing stock and hold the potential for significant energy use and GHG emission reductions. Many MURBs in the Lower Mainland are aging and require envelope and mechanical system upgrades to improve the buildings' energy efficiency as well as making them more comfortable spaces to live in. These capital renewal projects provide opportunities to replace gas fired space heating, DHW, and ventilation equipment with electrically driven HP technologies.

This project has documented six case studies of HP retrofits as well as one in-suite HRV retrofit application in MURBs in the Lower Mainland. The case studies contain descriptions of the building and equipment installed, high-level business cases, site pictures and interview summaries with Strata councils, unit owners, maintenance managers, and consultants on the rationale for the technology retrofit and their user experience. The case studies are meant to encourage technology uptake among building owners as well as inform updates to the City's Existing Building Retrofit Strategy.

Project results show that HP retrofits in MURBs are still limited in the Lower Mainland. While the potential benefits are large in terms of energy and carbon savings and improved comfort, several barriers prevent Strata corporations and private landlords from implementing retrofits of electrically driven technologies. Relatively high implementation costs, moderate energy cost savings, and insufficient electrical capacities at the building scale make business cases unattractive. In addition, building owners are often unaware of new HP technologies, avoid taking risks, and have little time and expertise in retrofit project management.

BC Housing is at the forefront of HP retrofits. Three out of six case studies are public housing sites owned and operated by BC Housing. Due to B.C.'s carbon neutral government mandate, the organization can accept higher upfront costs and longer paybacks than private building owners, which is good for industry capacity building and learning.

Another major finding of this project is that the popularity of in-suite solutions, such as ductless HRVs and through-wall HPs, has increased among owners who seek improved heating, cooling, and ventilation. While such units are often not big energy savings devices on their own, they can enable energy savings and improve air circulation.

In order to accelerate the market uptake of energy efficient measures and fuel switching technologies, the development of incentives, price signals, and regulation is recommended. Other solutions consist of advertising the non-energy benefits of fuel switching technologies among MURBs and developing turn-key programs that support owners with retrofit project management.

While the retrofit application of HPs, in particular of building scale equipment, is still uncommon in the Lower Mainland and in North America more generally, there is considerable interest in and need for energy efficient retrofits of MURBs. Product innovation and awareness of electrically driven heating and ventilation technologies have increased among industry stakeholders and building owners. More pilot projects, stakeholder engagement, energy assessments and incentives are needed to identify champions, reduce barriers and increase awareness among building owners. If implemented, these measures will pave the way for large energy and GHG savings and healthier spaces for Vancouverites to live in.

13. References

BC Hydro, 2017, Residential Rates, Residential Conservation Rate for Quarter 1, 2017

<https://www.bchydro.com/accounts-billing/rates-energy-use/electricity-rates/residential-rates.html>

(Accessed June 8th, 2017)

British Columbia Ministry of Environment (BC MOE), 2016, 2016/17 B.C. Best Practices Methodology for Quantifying Greenhouse Gas Emissions including Guidance for Public Sector Organizations, Local Governments and Community Emissions, Victoria

<http://www2.gov.bc.ca/assets/gov/environment/climate-change/cng/methodology/2016-17-pso-methodology.pdf> (Accessed July 12, 2017)

Carrier Residential Heat Pumps, Performance [™] 13 Heat Pump 38QRR

<http://www.carrier.com/residential/en/us/products/heat-pumps/38qrr/> (Accessed August 1, 2017)

Carrier Performance Series Horizontal Heat Pumps and Air Conditioners

<http://www.utcccs-cdn.com/hvac/docs/1010/Public/08/01-825-067-25.pdf> (Accessed August 1, 2017)

City of Vancouver (COV), 2017, Update on Energy Retrofits for Existing Buildings, Council Presentation, Planning, Urban Design & Sustainability, February 7, 2017

<http://council.vancouver.ca/20170207/documents/rr4Presentation.pdf> (Accessed July 20, 2017)

Clima Design Technologies Ltd., Products, Air Conditioning without an outdoor unit

<http://www.climadesigntech.com/products>, (Accessed August 1, 2017)

Innova Renewing Energies, Products, 2.0 FCU – WITH INTEGRATED FANCOIL

<http://www.innovaenergie.com/en/products/air-conditioner-2-0/2-0-fcu-with-integrated-fancoil/> (Accessed August 1, 2017)

Innova Renewing Energies, 2.0 Installation Manual

http://www.innovaenergie.com/wp-content/uploads/2012/06/N273026C_2.0_Man_Inst_Rev00_EN.pdf

(Accessed August 1, 2017)

Innova Renewing Energies, 2.0 Product Catalogue 2017

http://www.innovaenergie.com/wp-content/uploads/2017/02/2.0_Catalogo2017_WEB.pdf (Accessed August 1, 2017)

Lunos Canada, Lunos e2

<http://www.lunoscanada.com/lunos-e%C2%B2.html> (Accessed August 1, 2017)

Lunos Domestic Ventilation Systems With Heat Recovery, Innovations for New Buildings and Redevelopment, e2 series brochure

<http://www.lunoscanada.com/assets/e2-ego-brouchure.pdf> (Accessed August 1, 2017)

Sanden, Sanden SANCO2 Heat Pump Water Heater, Products

<https://www.sandenwaterheater.com/products/> (Accessed August 1, 2017)

Sanden, Sanden SANCO2 Heat Pump Water Heater, Professionals, Brochure and Specifications

https://www.sandenwaterheater.com/sanden/assets/File/SANDEN_CO2WaterHeater_9_16.pdf (Accessed August 1, 2017)

Sanden, Sanden SANCO2 Heat Pump Water Heater, Homeowners, Owner's Manual

https://www.sandenwaterheater.com/sanden/assets/File/Sanden_40950-44672_owners-manual.pdf (Accessed August 1, 2017)

Toronto Hydro, 2017, Appliance Usage Chart, Effective July 1, 2017

<http://www.torontohydro.com/sites/electricsystem/residential/yourbilloverview/Pages/ApplianceChart.aspx> (Accessed July 15, 2017)

Trane, Products, Horizon, Dedicated Outdoor Air Systems

<http://www.trane.com/commercial/north-america/us/en/products-systems/equipment/unitary/dedicated-air-solutions/dedicated-outdoor-air-systems.html> (Accessed August 1, 2017)

Trane, 2016, Product Catalogue, Horizon™ Outdoor Air Unit For 100% Outdoor Air Applications, Models: OABD, OABE, OADD, OADE, OAGD, OAGE, OAKD, OAKE, OAND, OANE, June 2016

http://www.trane.com/content/dam/Trane/Commercial/global/products-systems/equipment/unitary/dedicated-air-solutions/OAU-PRC001G-EN_06172016.pdf (Accessed August 1, 2017)

Uren, D., 2013, Halsall Associates, Condovoice Fall 2013, Condominium Owners, Make-up Air Units, What every Unit Owner should know

<https://powervac.ca/wp/wp-content/uploads/2015/07/condovoice-fall-2013-make-up-air-units-what-every-unit-owner-should-know.pdf> (Accessed August 1, 2017)

475 High Performance Building Supply, Products, Ventilation, Lunos Installation Manual, duct-less ventilation system with heat recovery, type e2 and e2 short

https://foursevenfive.com/wp-content/uploads/2016/08/e2_installation_instructions.pdf (Accessed August 1, 2017)