

# H O M E O W N E R ' S   G U I D E   T O



# ELEC TRI FI CA TION

Prepared by:

Shikhar Kumar, UBC Sustainability Scholar, 2020

Date: 31<sup>st</sup>-July-2020

Prepared for:

Brady Faight, P. Eng, Green Buildings Engineer

City of Vancouver | Sustainability

## City of Vancouver Projects Disclaimer

This report was produced as part of the Greenest City or Healthy City Scholars Program, a partnership between the City of Vancouver and the University of British Columbia, in support of the Greenest City Action Plan and the Healthy City Strategy.

This project was conducted under the mentorship of City staff. The opinions and recommendations in this report, and any errors, are those of the author, and do not necessarily reflect the views of the City of Vancouver or The University of British Columbia.

The following are official partners and sponsors of the Greenest City or Healthy City Scholars Program:



THE UNIVERSITY OF BRITISH COLUMBIA  
**sustainability**

## Acknowledgements

The author would like to thank the following individuals for their contribution, feedback, and support throughout this project.

- Wayne White (Deputy City Electrician, COV)
- Chris Higgins (Green Building Planner, COV)
- Ian Neville (Senior Sustainability Specialist, COV)
- Brady Faught (Green Buildings Engineer, COV)
- Micah Lang (Senior Green Building Planner, COV)
- Sean Pander (Green Building Manager, COV)
- Dan Trudel (ElectrumCharging)
- Jordan Fisher (Fresco Ltd.)
- Robert Redford (Redford Electric)
- Steve Abercrombie (Powerpros)
- Albert Rooks (Small Planet Supply)

## Table of Contents

<b>Executive Summary</b> .....	<b>4</b>
<b>1.0 Introduction</b> .....	<b>5</b>
<b>1.1 Identifying the kind of Electrical Panels in Older Homes.</b> .....	<b>6</b>
<b>1.2 Modern Electrical Panel System</b> .....	<b>9</b>
<b>2.0 Reasons to Complete an Electrical Panel Upgrade</b> .....	<b>12</b>
<b>2.1 Average Cost of Panel upgrade</b> .....	<b>14</b>
<b>2.2 Alternative to Electrical Panel Upgrades.</b> .....	<b>19</b>
<b>2.2.1 Demand Charge Controller Or DCC</b> .....	<b>19</b>
<b>2.2.2 Dryer Buddy</b> .....	<b>20</b>
<b>2.2.3 Load Miser Energy Divider Controller</b> .....	<b>21</b>
<b>3.0 Switching to All Electric Home &amp; Its Benefits</b> .....	<b>23</b>
<b>3.1 Heat Pumps Air Conditioning System</b> .....	<b>24</b>
<b>3.2 Heat Pump Water Heaters</b> .....	<b>28</b>
<b>3.3 Induction Stove &amp; Cooktop</b> .....	<b>30</b>
<b>3.4 Heat Pump Dryer</b> .....	<b>33</b>
<b>3.5.0 Smart Home Devices</b> .....	<b>35</b>
<b>3.5.1 Smart Thermostat</b> .....	<b>35</b>
<b>3.5.2 Smart Home Energy Manager.</b> .....	<b>37</b>
<b>3.6 Electric Vehicles &amp; Residential EV Charging</b> .....	<b>39</b>
<b>4.0 Energy Efficient Homes &amp; EnerGuide Audit</b> .....	<b>45</b>
<b>4.1 Making Small Changes that Add Up</b> .....	<b>47</b>
<b>5.0 Incentive &amp; Rebate Programs</b> .....	<b>50</b>
<b>5.1 Electrical Service Upgrade Rebate</b> .....	<b>52</b>
<b>5.2 Energuide Home Evaluations Rebate</b> .....	<b>53</b>
<b>5.3 Home Energy Improvement Bonus</b> .....	<b>54</b>
<b>6.4 Electric Heat Pump Water Heater Rebate (Convert from Fossil Fuel)</b> .....	<b>54</b>
<b>5.4 Air Source Heat Pump Rebate (Convert from Fossil Fuel)</b> .....	<b>55</b>
<b>5.5 CleanBC Go Electric EV Charger Rebate</b> .....	<b>57</b>
<b>6.0 Future Research Prospects.</b> .....	<b>59</b>
<b>7.0 References</b> .....	<b>60</b>

**Table of Figures**

Figure 1: Knob & Tube wiring ..... 7

Figure 2:60-amp service panel .....8

Figure 3: Bringing power from pole to home. ....9

Figure 4: Electrical Panel .....10

Figure 5: Single pole circuit breaker .....11

Figure 6:Double pole circuit breaker .....11

Figure 7:AFCl .....11

Figure 8:GFCI .....11

Figure 9: wiring of sub-panel .....12

Figure 10: Circuit breaker vs Fuse box.....13

Figure 11: Before & after fuse box upgrade to panel.....18

Figure 12: basic heat pump cycle. ....24

Figure 13: Heat Pump Air Conditioning .....25

Figure 14: ENERGY STAR logo .....27

Figure 15: Typical Heat Pump Water Heater.....28

Figure 16: Induction Stove.....30

Figure 17: Induction Cooktop .....32

Figure 18:Typical Heat Pump Dryer.....33

Figure 19: Smart Thermostat.....35

Figure 20: Typical Energy manager installation.....37

Figure 21: User interface dashboard .....38

Figure 22: Typical Charging Connector .....42

Figure 23: Typical installation of DCC .....20

Figure 24: Typical Dryer Buddy.....21

Figure 25: AC Dandy Load miser switch .....22

Figure 26: Typical EnerGuide Report.....45

Figure 27: Improving energy efficiency of the home. ....48

## **Executive Summary**

This paper is extensively focusing on the existing electrical system of single-family homes in Vancouver and the barriers to adding electric loads. It first investigates the kind of homes in Vancouver, which still has an outdated electrical system or limited electrical panel capacity and the recommended solution for such scenarios, which is a service upgrade. Upgrading the electrical panel and infrastructure can be very costly to a homeowner, and the paper talks in detail about upgrade triggers, cost of service upgrade and other technical challenges to look for; so that homeowner is well informed about the existing system and can factor in the additional cost into their budget. It also talks about the benefit of electrifying the homes, how much would it cost the homeowners to switch from all gas appliances to all-electric and some potential technological solutions that can be deployed at home to manage increasing load demand and help reduce the energy usage and utility bill. Finally, it talks about potential rebate programs that will help homeowners curb the cost of upgrades, how to make a home more energy-efficient by making small changes and topics for future research opportunities.

## **1.0 Introduction**

In January 2019, Vancouver City Council unanimously approved a motion recognizing the climate emergency that the planet faces, acknowledging that Vancouver needs to do more to reduce carbon pollution in response to that emergency. In British Columbia, 94% of the electricity is clean electricity coming from hydro and other renewable sources, which is very fortunate. However, it is the burning of natural gas that accounts for significant greenhouse gas emissions in the city. Nearly 60% of GHG emissions in Vancouver comes from burning fossil fuels in buildings & homes for heating and cooking purposes. The city's response to deal with the climate emergency is to reduce GHG emissions by 45% below the 2010 level by 2030. They plan to do so by electrifying new & existing homes and replacing all the traditional heating & hot water systems with heat pumps. A primary barrier to electrifying many existing old homes is either an outdated electrical system or limited electrical panel capacity (i.e. 100 amps or less in many homes). Most modern electric appliances and heat pumps require dedicated 240 V supply and draw high current so, it is essential to ensure that existing system is capable of handling increased load demand, or it could be a hazardous situation (i.e. electric fires because of overloading and overheating of the electric panel).

## 1.1 Identifying the kind of Electrical Panels in Older Homes.

**Pre-1950 Homes:** If the house is built before 1950 and no electrical work is done in the house till date then highly likely it has a Knob & Tube panel system. It refers to a specific type of wiring that runs from the electrical panel to the lights, switches and outlets throughout the house. The term “Knob & Tube” comes from the design which uses porcelain knobs and when running through wooden beams they were protected by porcelain tubes. Some of the important characteristics are:

1. They use a heavy gauge copper wire, thicker than the standard modern wire in new homes.
2. All wire-to-wire connections are soldered which makes it very robust system.
3. The two electrical conductors of the knob & tube circuit are separated 6” or more from each other.

Modern day electrical equipment’s like toasters, computers, refrigerators etc. requires a ground wire for safety, which is missing from knob & tube system. In event of electrical fault like sparks or shocks, it will damage your appliance and might cause a fire. If the house was built before 1950 and no electrical work is done till date, then it’s *highly recommended* to upgrade the electric panel. Also, for home-insurance purposes its recommended to do the upgrade to lower the monthly

premium. Contact a registered local electrician or electrical contractor to get an audit and proceed accordingly.

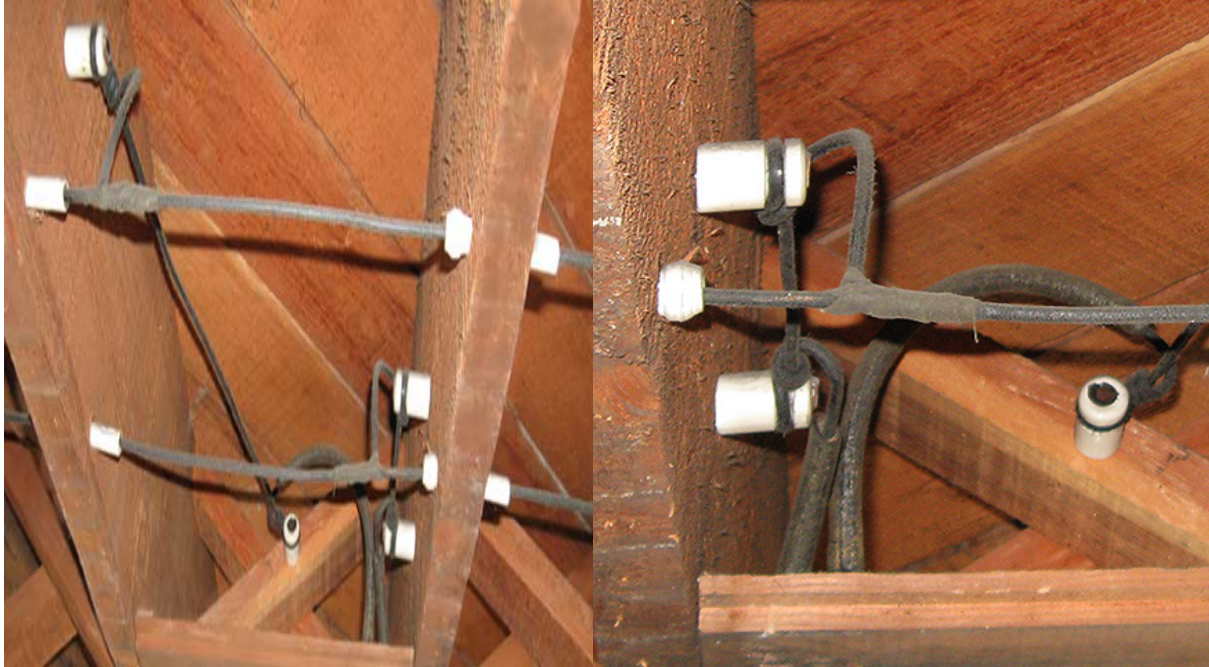

Figure 1: Knob & Tube wiring

**1950-1970s home:** Most houses which are built between 1950 and 1970s have a 60-amp service. These houses have old wiring, doubled-up circuits and an electrical panel with old fuse systems. These 60-amp panels are usually overloaded or hazardously upgraded with wrong size of the fuse. Modern day appliances draw a lot of current, in order to reduce blowing up the fuses or tripping of circuit breaker, they are replaced with higher rating breakers which is not safe and have higher risk of fire hazard. It is *highly recommended* to upgrade to a larger service panel to reduce chances of fire hazards. Also, it will give homeowners enough room for expansion in the future and increase the re-sale value of the home.





Figure 2:60-amp service panel

**1970s homes or later:** Homes built during this time most likely to have a 100-amp combination panel with main breaker and branch circuit board. They are relatively safe and reliable. If the breaker is sized correctly based on the demand of the house and there's no damage or existing safety issues, the homeowner most likely does not need to upgrade to accommodate additional electrical services. Contact a registered local electrician or electrical contractor to check the situation of the electrical panel and proceed accordingly.

## 1.2 Modern Electrical Panel System

An electrical panel also known breaker panel, service panel, breaker box is a steel box that holds multiple circuits that distributes power throughout the home. The power enters from the poles into the panels, through the breakers and out to the circuits. A typical electrical panel consists of following components:

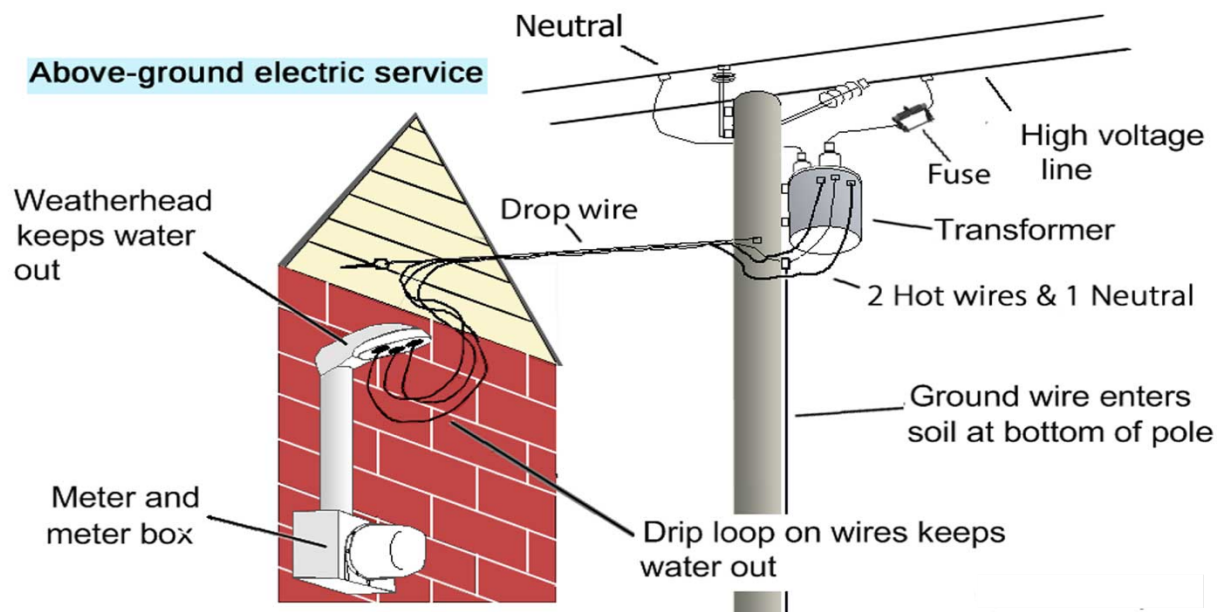

Figure 3: Bringing power from pole to home.

*Main breaker:* It is large usually double-pole circuit breaker that limits the amount of current/electricity coming in from the poles. Its main job is to protect the circuits inside the panel. It also identifies the maximum amperage capacity of the panel i.e. that's the max amount of current it can handle.

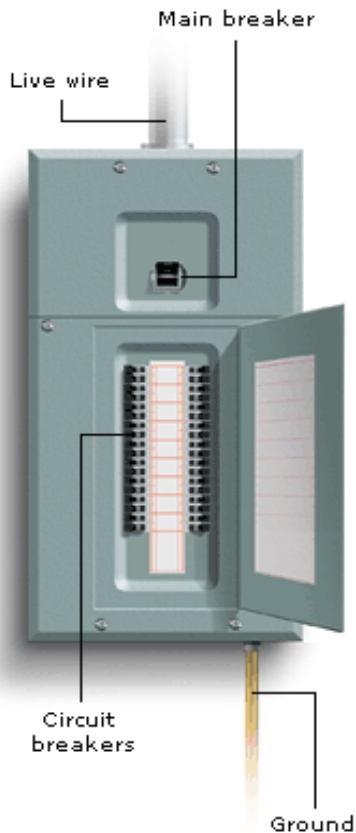

Figure 4: Electrical Panel

*Circuit Breakers* It is an automatic electrical switch (also known as thermal magnetic trip device) that turns the power to the home off or “trips” when it detects an electrical shortage or overcurrent. This turning off or tripping action protects wiring and appliances from damage or in worst case fire. The best advantage of circuit breaker is that it doesn’t need to be replaced after single use, instead it can be manually reset after it trips. They basically come in multiple sizes and types depending on the requirement. An

electrical contractor will be better to identify in detail what size or type is needed in your house. Below are some options:

*Single pole:* These circuit breakers provide 120 volts in various amperage ratings. Typically, a 15-20 amp rated breakers are used for lighting & receptacles.

*Double pole:* these circuit breakers provide 240 volts in various amp ratings. Typically, used for electric appliances, hot water heaters and EV charging stations.

*AFCI:* Arc fault circuit interrupters are modern circuit breakers designed to shut down power to a circuit when it detects arcs of electricity caused by either worn or damaged wires. Mostly used to protect circuits in bedroom and living areas.

**GFCI:** Ground fault circuit interrupters trips the circuit instantly when it detects short circuit. They are used to mostly in wet locations like bathrooms, garages, kitchen.



Figure 5: Single pole circuit breaker

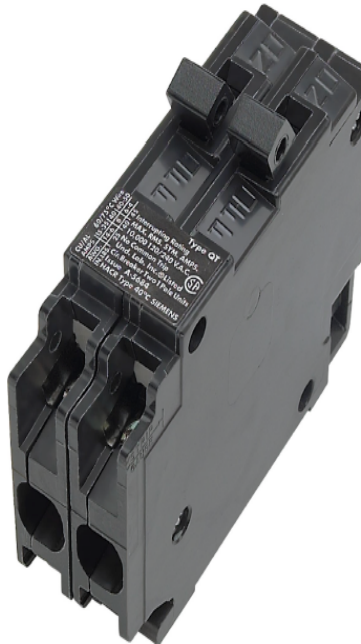

Figure 6: Double pole circuit breaker



Figure 7: AFCI



Figure 8: GFCI

**Sub-Panel:** It is a smaller electrical panel that services a specific area of the home. It usually contains new circuits which helps to either expand or readjust energy distribution to better handle the usage of electricity.

Note 1: It is only a good solution when main breaker panel doesn't have spare slots to add a new circuit. It does not increase the amount of available power.

Note 2: It is powered by a circuit from within the main panel and it does not have its own disconnect.

Note 3: The amp rating of the circuit in the main breaker must be same or smaller than rating of the sub-panel connected to it. For example: if sub-panel is rated to 40 amps, the max amperage of the circuit in the main breaker would be 40 amps as well.

Note 4: The only limit for the number of sub-panels is the number of available circuits in the main breaker panel.

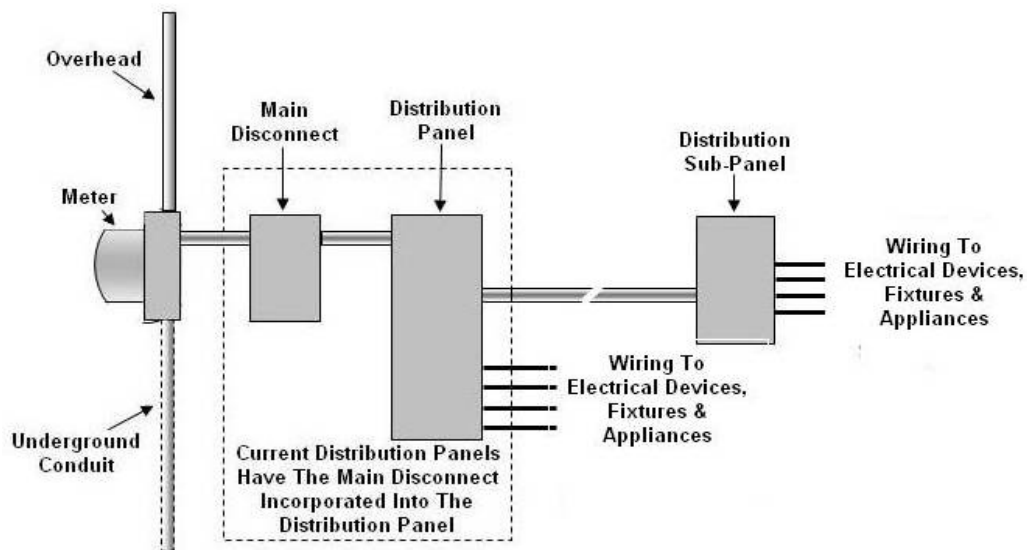

Figure 9: wiring of sub-panel

## 2.0 Reasons to Complete an Electrical Panel Upgrade

⇒ Old residential homes offer a cozy and retro feeling. This is not present in modern houses. However, these older homes with obsolete electrical panels may not be able to support modern electrical needs. If the house has an old knob & tube wiring or 60-amp service, homeowner may want to consider upgrading the electrical panel to 100 to 200 amps. A larger panel would provide future

proofing for additional electric loads in the long-term.

⇒ Fuses have become outdated. Circuit breakers are more efficient and provide major safety feature. They trip off when there's overload. So, upgrading the electrical panel will not only ensure steady flow of electricity but also prevents potential electrical fire hazards. *That means no flickering of lights, no electric shocks, no smell of burning, no more sparking on power outlets and definitely no more pain of replacing fuse boxes.*

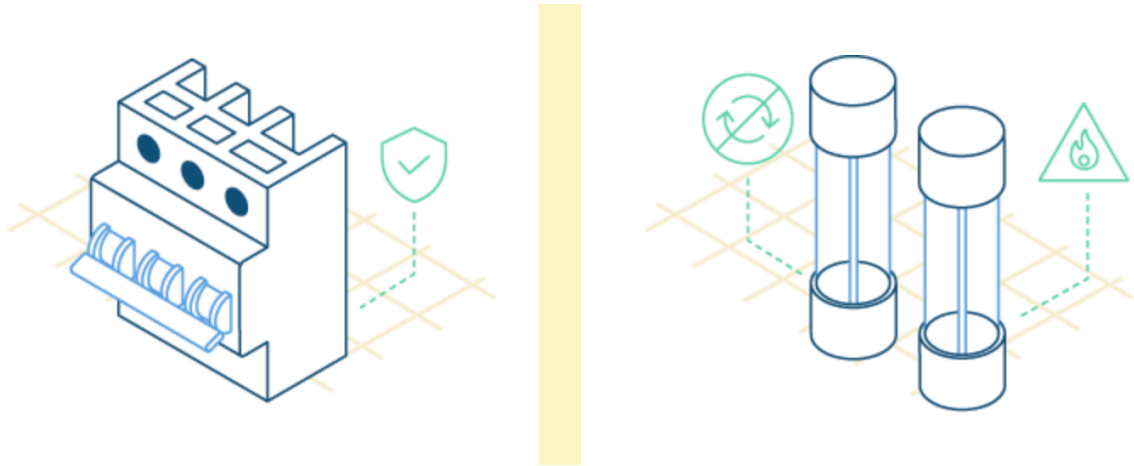

Figure 10: Circuit breaker vs Fuse box

⇒ Most electrical appliances now require 240V circuit including most heat pumps, electric ranges, EV charging station etc. and they draw a lot of current (upto 80 amps for level 2 EV charges). If the homeowner is looking to add any of those in their homes, chances are the electrical panel may not be able to handle the workload required to power the new appliances. Upgrading it to 200-amp panel will give enough room to add all the new appliances without any issues. Also, as

per Canadian Electrical Code 2018, no electrical circuit should sustain loads of more than 80% the maximum capacity. That means on a 100-amp panel, a homeowner can only load it up to 80 amps. So, its recommended to check with an electrician, do an electrical load calculation to see if the existing panel has enough room for addition of new circuits, otherwise the homeowner should consider a panel-size upgrade.

⇒ In addition, an electrical panel upgrade can help in reducing homeowner's insurance bills (*most insurance companies are asking for a minimum 100-amp electrical service prior to insuring an older home*). It also helps in increasing the value of the home. The new electrical panel with breakers are aesthetically pleasing and gives a peace of mind as it's not a hazard it once was.

⇒ At time of writing, there are active rebate programs offered by the city, provincial and federal government that will help to curb the cost of the panel upgrade so definitely something to consider for.

## **2.1 Average Cost of Panel upgrade**

**MATERIAL COST:** *estimated approx. \$3500* (Price may vary based on the size of the panel and number of breakers needed. Please check final price through registered electrical contractor). Available brands in market include Siemens, Eaton, GE, Leviton etc.

**BC HYDRO SERVICE CHARGE:** (detailed info available on BC-Hydro website)

<b>AMPS</b>	<b>ZONE I</b>	<b>ZONE II &amp; IB</b>
<b><i>OVERHEAD SERVICE</i></b>		
New connection service		
100 amps	<b>\$799 plus GST</b>	<b>\$1,110 plus GST</b>
200 amps	<b>\$838 plus GST</b>	<b>\$1,149 plus GST</b>
400 amps	<b>\$1,207 plus GST</b>	<b>\$1,560 plus GST</b>
Relocation/alteration or disconnect/reconnect for electrical work (existing wire)		
Up to 200 amps	<b>\$860 plus GST</b>	<b>\$1171 plus GST</b>
400 amps	<b>\$924 plus GST</b>	<b>\$1235 plus GST</b>
Alteration/upgrade (new wire)		
100 amps	<b>\$948 plus GST</b>	<b>\$1259 plus GST</b>
200 amps	<b>\$978 plus GST</b>	<b>\$1298 plus GST</b>
400 amps	<b>\$1249 plus GST</b>	<b>\$1560 plus GST</b>
Temporary service	<b>\$883 plus GST</b>	<b>\$883 plus GST</b>
<b>UNDERGROUND SERVICE</b>		
New Service Connection		



100 amps	<b>\$948 plus GST</b>	<b>\$1259 plus GST</b>
200 amps	<b>\$1270 plus GST</b>	<b>\$1298 plus GST</b>
400 amps	<b>\$2225 plus GST</b>	<b>\$1560 plus GST</b>
Alteration/upgrade (new wire)		
200 amps	<b>\$1342 plus GST</b>	<b>\$1653 plus GST</b>
400 amps	<b>\$2225 plus GST</b>	<b>\$2691 plus GST</b>
Temporary Service	<b>\$957 plus GST</b>	<b>\$957 plus GST</b>

<b>METERS</b>		
Request an additional meter during initial installation	<b>\$46 plus GST</b>	<b>\$46 plus GST</b>
Request an additional meter subsequent to initial installation	First meter is <b>\$181 plus GST</b> . Additional meters are <b>\$46 plus GST</b>	First meter is <b>\$181 plus GST</b> . Additional meters are <b>\$46 plus GST</b>
Request a meter removal	<b>\$181 plus GST</b>	<b>\$181 plus GST</b>
Meters checked and resealed after disconnection	<b>\$181 plus GST</b>	<b>\$181 plus GST</b>
Current Transformer (CT) and potential transformer (PT) wiring for service larger than 200 amp	<b>\$586 plus GST</b>	<b>\$586 plus GST</b>

<b>OTHER CHARGES</b>		
Service connection call-back charge (if site and/or equipment isn't ready when crews arrive)	<b>\$368 plus GST</b>	<b>\$766 plus GST</b>

<b>RECONNECTION CHARGES</b>	<b>COST</b>
Standard reconnection charge	<b>\$30 plus GST</b>
Manual- overtime reconnection charge	<b>\$280 plus GST</b>
Access refusal reconnection charge	<b>\$700 plus GST</b>

**Zones Description:**

- **ZONE I:** Include Kingsgate-Yahk, Lardeau-Shutty Bench and rest of British Columbia excluding the areas outlined in ZONE IB & ZONE II below.
- **ZONE IB:** Bella Bella
- **ZONE II:** Anahim Lake, Atlin, Bella Coola, Dease Lake, Elhateese, Fort Ware, Good Hope Lake, Haida Gwaii, Hartley Bay, Jade City, Telegraph Creek, Toad River & Tsay Key.

**CITY PERMIT: \$150 plus GST** (*forms available on City of Vancouver website*)

**ADDITIONAL COST: Price varies.** This includes labor cost, replacing old wiring with new ones, conduit work, moving the electrical panel from one location to other, digging a trench for wiring, upgrading the meter socket, etc. A certified electrician or an Electrical contractor will give the homeowner a complete quote based on the condition of the house and doing an audit of the existing electrical system.

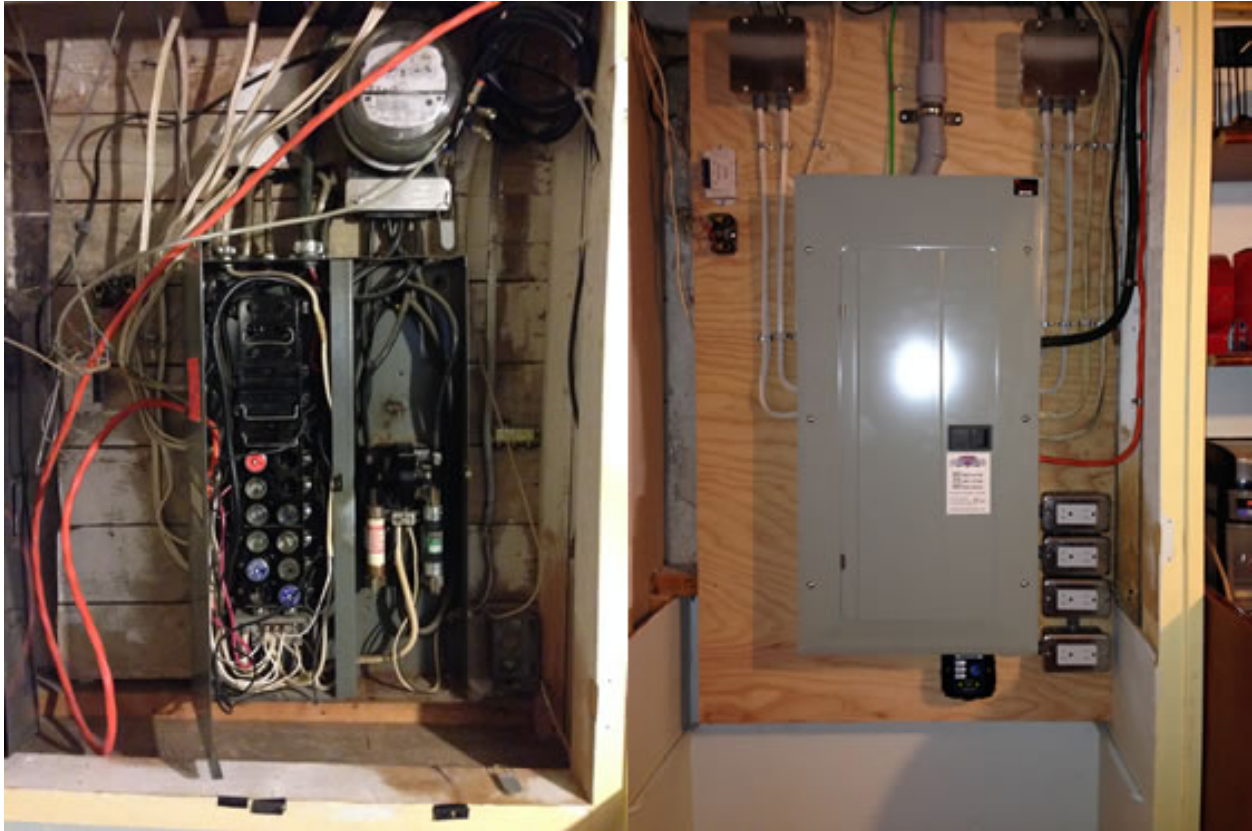

*Figure 11: Before & after fuse box upgrade to panel*

**Note 1:** Doing any kind of electrical work in the house whether service upgrade or electric appliance installation most likely requires a permit. It is recommended to the homeowners to check with the city office if they need permit and apply for the same.

**Note 2:** After filling the permit form, a city inspector does an inspection to determine if an installation is code compliant. If it fails inspection, then they note down the deficiencies and recommend necessary actions.

## **2.2 Alternative to Electrical Panel Upgrades.**

If a homeowner already has a 100/125-amp electrical panel with breakers and is only looking to add a heat pump and/or EV charger, they can easily do it by installing an EV smart energy management system and can skip the hassle of electrical panel upgrade. Below mentioned are couple of companies available in the market which offers the smart system to efficiently handle additional electrical load in homes.

**Note 1:** As per Canadian Electrical Code 2018(refer to section 8-106, see appendix), if the homeowner's annual energy usage is significantly low for 1 year (reviewing the utility bill of past 1 year) the panel may be able to accommodate additional loads without requiring a panel service upgrade. They can just do that to the existing 100/125-amp panel. Its recommended to definitely check with the electrician or an electrical contractor to determine if this is possible.

### **2.2.1 Demand Charge Controller Or DCC**

DCC-10 is an energy management system designed to allow the connection of an EV Charger to a panel that is at full capacity and would otherwise need a service upgrade.

### System Operation & Features:

- Real-time reading of the total power consumption of the home electrical panel.
- Detects when total power consumption exceeds 80% of main circuit breaker capacity and temporarily de-energize the EV charger and re-energizes when the demand falls below 80% for more than 15 mins.
- Requires one double pole breaker slot available in a panel i.e. 208/240 V single phase dedicated circuit. It draws current from 30-60 amps depending on model bought.
- Would require a NEMA 3R enclosure for outdoor installation.
- Does not affect load calculation of a panel.
- Automatic billing of electricity by the utility (for condo installation)
- Includes in the box is charge controller, EV charger breaker & 2 split core CT.
- Price max up to \$1150 plus taxes. Installation charges separate.

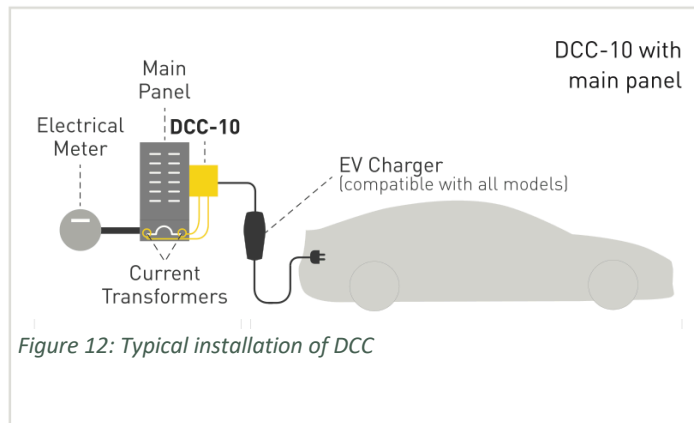
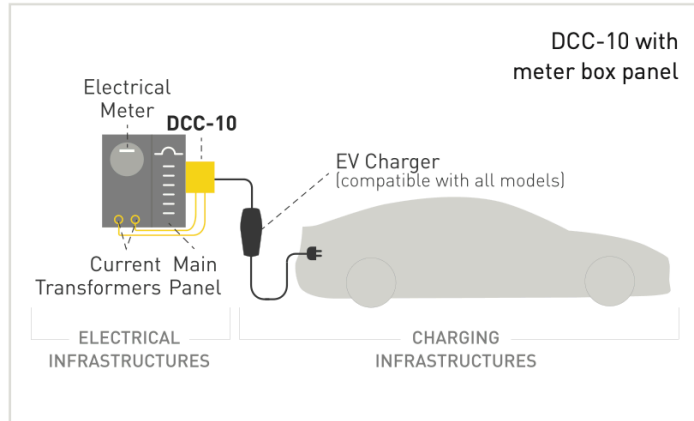

Figure 12: Typical installation of DCC

## 2.2.2 Dryer Buddy

The Dryer Buddy Plus AUTO is a fully automatic 2-way switcher that allows homeowner to share the dryer outlet with EV Charging (also called EVSE) without having to flip any switches. It functions by keeping the dryer outlet live and EVSE outlet only live when there is enough amperage available to charge the EV.

When the dryer is off it draws almost 0 amps so the EVSE outlet is switched on allowing EV to charge. If the dryer is turned on at any time then the EVES outlet is switched off, when the dryer is done, power is restored to the EVES outlet and if the EV needs charging, it will resume back to charging mode.

Note: Set the EV charging station to 24amps or less when using Dryer buddy. It needs a dedicated 240v circuit and draws up to 30 amps current. Price max up to \$ 500 plus installation charges separate. Available in multiple options & combinations.



Figure 13: Typical Dryer Buddy

### 2.2.3 Load Miser Energy Divider Controller

It is an ideal cost and energy saving device. It is best suited in cases when electrical panel capacity is limited, and the homeowner is looking to add a heat pump/ electric vehicle charger to the home.

System Operation & Features:

- It is specifically designed as a load saving device, to be used where non-essential load is connected to an essential load circuit.
- It only cuts off power to the non-essential circuits. This helps to save on service upgrades.

- It requires a dedicated 240 V circuit and draws current from 5-50 amps.
- Easy to install for new and existing installations. It gets connected in series with the existing circuit.
- It can be programmed to prevent non-essential load from operation on/off hour, increasing energy savings and allowing non-essential load to operate on/off time energy availability.
- Its CSA certified and comes with NEMA 3R enclosure.
- For pricing, contact AC Dandy or a local distributor.

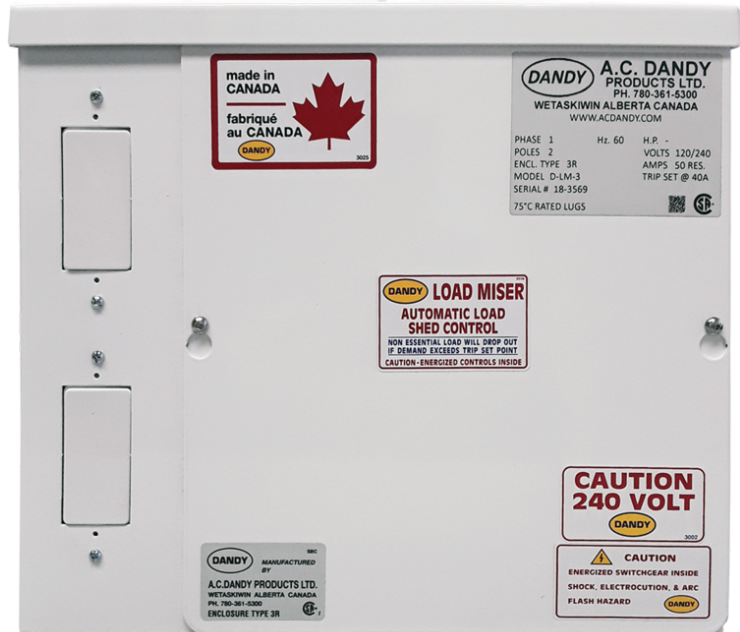

Figure 14: AC Dandy Load miser switch

***See Section 3.6 for information on EV charging.***

### **3.0 Switching to All Electric Home & Its Benefits**

Natural gas used in residential and commercial buildings is responsible for 60% of the City of Vancouver's climate-warming greenhouse gas emissions. This makes electrification which is shifting from using traditional gas-based appliances and heating system to those that are powered by electricity an important strategy in meeting British Columbia's climate goals and in the process can save homeowners and renters upfront and operating costs. The use of natural gas inside buildings for heating and cooking also has major public health impacts. Burning gas in household appliances produces damaging level of pollutants like Carbon monoxide, nitrogen dioxide, formaldehyde and ultrafine particles which causes serious long-term health impacts like asthma and other respiratory diseases.

Using all electric appliances not only improves indoor and outdoor air quality but also increases public safety by reducing chances of fire caused by using gas for cooking. Overall it will make home healthier and safer, making the quality of life better for its residents. Another important reason for electrifying the homes is that Vancouver falls under seismic zone i.e. a higher risk of earthquakes happening, and gas appliances are not safe for obvious reasons. Also, in a worst-case natural disaster scenario it takes forever to repair gas pipelines.



### 3.1 Heat Pumps Air Conditioning System

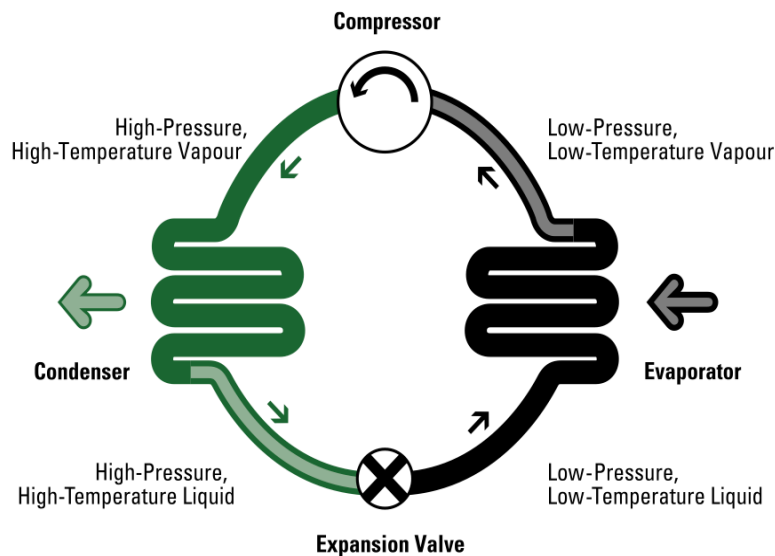

Figure 15: basic heat pump cycle.

A heat pump air conditioning system is an energy-efficient way to heat and cool home all year round. It is an electrical device that extracts heat from one place and transfer into another. It transfers heat by

circulating a substance called a

refrigerant through a cycle of evaporation and condensation (see fig:11). A compressor pumps the refrigerant between two heat exchangers coils. In one coil, the refrigerant is evaporated at low pressure and absorbs heat from its surroundings. The refrigerant is then compressed en route to the other coil, where it condenses at high pressure. At this point, it releases the heat it absorbed in the cycle. The heat pump cycle is fully reversible, and heat pumps can provide year-round climate control for the home which is heating in winter and cooling and dehumidifying in summer. Heat pumps are very efficient and a cleaner alternative to a gas furnace/boiler.

## Benefits of Heat Pump Air Conditioning System

- ◆ Heat pumps can help save money on energy costs compared to less efficient heating and cooling systems.
- ◆ They are highly energy efficient as for the fact that they don't create heat, they move heat from one place to another.
- ◆ Heat pump produces almost negligible harmful greenhouse gas and helps protect the environment.
- ◆ Heat pumps eliminates the risk of carbon monoxide poisoning and other respiratory illness that are caused with natural gas or propane.
- ◆ It provides good air filtration and dehumidification. Air quality is improved a lot which is a big advantage for adults or kids with allergies related to air pollution.
- ◆ They provide comfort and control to the user. Latest heat pump technologies can provide zone control and temperature control at an ease. There are several options available in the market currently and homeowners can buy these as per need and price they are willing to pay.

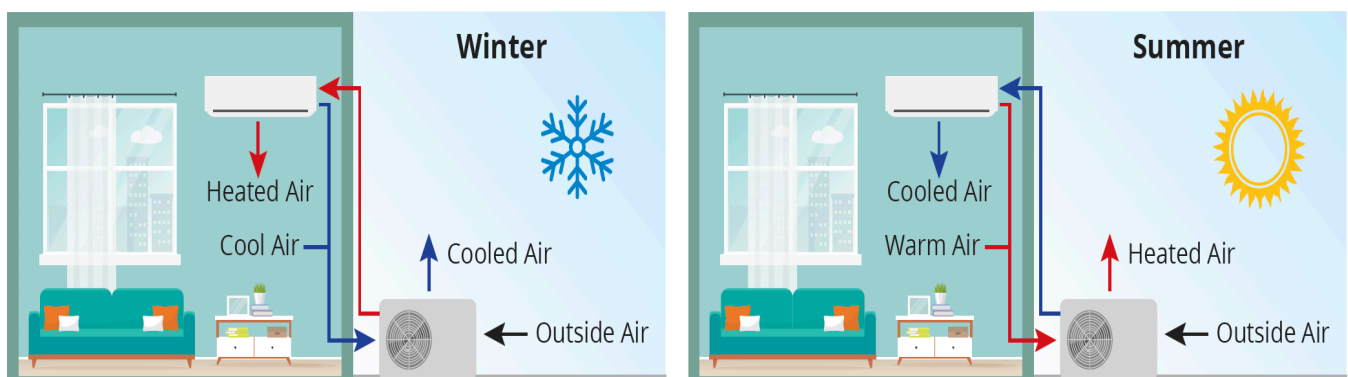

Figure 16: Heat Pump Air Conditioning

## **Types of Heat Pump Available in Market.**

- **Air-Source Heat Pump:** This is the most common heat pump option available in market. There's an outside heat pump unit that works in conjunction with an indoor air handling unit to move warm air, acting as a cooling system in summer and heating system in winter. An air source heat pump can deliver one-and-a-half to three times more heat energy to a home than the electrical energy it consumes. They also have long life expectancy with little maintenance.
- **Variable refrigerant system (VRF):** This is the latest technology out in the market right now. It allows one outdoor condensing unit to be connected to multiple indoor unit with minimal energy loss. Cold-climate models are able to delivers heating down to  $-30^{\circ}C$  as standard.
- **Single-Zone Mini-Split System:** Its best suited for place where size is constraint like apartments and laneway houses. These are usually small, ductless units that provide zoned heating and cooling which can be easily managed by room or area.
- **Multi-zone ductless mini-split system:** It provides efficient heating and cooling at a lower operation cost with no hassle of ductwork changing. It is best suited for homes which doesn't have a well-designed central heating/cooling system.

## Typical Specification for Single/Multi-zone ductless mini-split system

- **Operating voltage:** 208/230V
- **Minimum circuit amp:** 17.2 – 30 amps (min to max)
- **Heating operating range:** –25°C to 24°C
- **Cooling operating range:** –10°C to 46°C
- **SEER:** 16-20
- **HSPF:** 9.3-12.5
- **Outdoor sound rating:** as low as 50dB
- **Unit Price:** varies from \$2500-\$5000+ labor and additional materials

(Ask a registered HVAC contractor/installer for an exact quote)



Figure 17: ENERGY STAR logo

**Note 1:** Always consider SEER (Seasonal energy efficiency ratio & it measures cooling efficiency) and HSPF (heating seasonal performance factor & it measures heating efficiency). To make sure the product is energy efficiency, always consider ENERGY STAR-certified products.

**Note 2:** It is recommended for the homeowner to first get a heat loss calculation from an experienced contractor or Energy Advisor and then get the sizing of the heat pump, to avoid oversizing of the equipment from a certified HVAC installer.

## 3.2 Heat Pump Water Heaters

Water heaters with new energy-efficient heat pump technology are a highly efficient way to heat water. It offers a reduction in energy usage and utility bill savings when compared to electric resistance water heaters and much more environmentally friendly than gas water heaters. It works exactly on the principle of heat pump cycle which is moving heat from one place to another.

### Benefits of Heat Pump Water Heaters.

- ◆ Heat pump water heaters are 3 times more efficient than the electric water heaters and almost 4 times more efficient than traditional gas water heaters.
- ◆ They help to reduce the utility cost in a long run, and they are environment friendly.
- ◆ They are equipped with enhanced technology which gives a lot more control and freedom to user with various operating modes and user-friendly settings to manage on demand of hot water by day, week or month basis or even settings for vacation time when away from home.

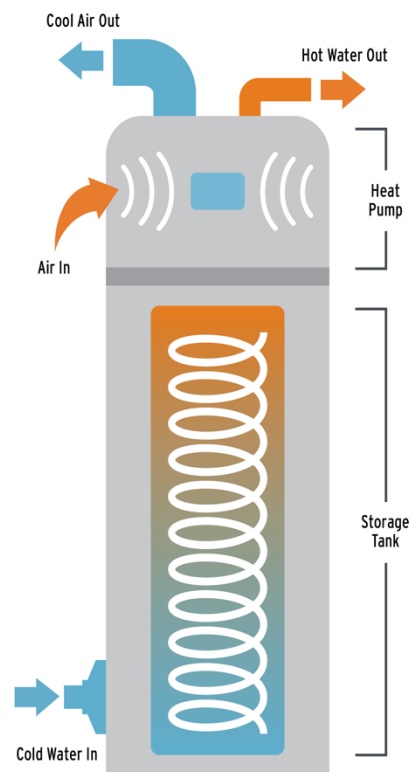

Figure 18: Typical Heat Pump Water Heater.

- ◆ Heat Pump water heaters are much safer than gas water heaters as there's no chance of leakage of gas. Also, they don't need ventilation as compared to gas water heaters.

### **Operating modes for added efficiency.**

- *Heat Pump only mode* which offers the highest energy efficiency. As the term says, it only relies on the heat pump to heat the water.
- *Hybrid or High demand mode* maintains high energy efficiency while introducing flexibility of demand response. The inbuilt electric resistance works as a backup when demand is too high for hot water. For normal use only heat pump heats the water.
- *Electric resistance only mode* offers the greatest demand response with least efficiency.
- *Vacation mode* offers high energy savings during times when residents are away from home for longer period of time *by putting the water heater to sleep mode.*

### **Note:**

- Most heat pump water heaters can be installed in the same location as a current water heater location in your home (ideally garage or basement). Make sure they have at least 1000  $ft^3$  of air flow around them.
- For a household of 3-4 people an 80-gallon heat pump water heater would be ideal. The bigger tank gives the benefit of operating in heat pump mode only than

switching to hybrid mode. Contact an expert installer to discuss the options best suited for the house.

- They require a 240V dedicated circuit in the electrical panel and draw almost 30 amps current. The noise rating can achieve as low as 45db.
- To make sure the product is energy efficient, always consider ENERGY STAR-certified products.
- Unit Price varies from \$1500 to \$4000 (Contact an HVAC installer to get final quote).

### 3.3 Induction Stove & Cooktop



*Figure 19: Induction Stove*

With so much advancement in technology, induction cooktops have revolutionized cooking in a great way with faster cooking time and much safer than traditional gas cooktops. They can be used both in residential and commercial spaces. They are easy to operate and clean and provide better indoor air quality relative to gas combustion products. They are highly energy efficient and environment friendly. On an induction stove, a cooking vessel is heated by electrical induction (also known as

magnetism), instead of by thermal conduction from a flame (gas stove) or an electrical heating element (electric range). The induction stove reverses a magnetic field back and forth very rapidly creating an alternating magnetic energy and sending into the metal pot, heating it up.

### **Benefits of Induction Cooktops:**

- ◆ Induction cooktops are much safer than the traditional gas burners as there's no open flames and no chances of gas leakage or line breaks as there's no gas line. It is well suited for family with kids as well as professional chefs.
- ◆ Induction cooktops generates a great deal of heat in a really short time and able to deliver almost 90% of heat for cooking compared to gas which is only 50% and electric range which is close to 75%.
- ◆ It gives a flexibility to raise or lower the temperate instantly. It also features instant on & off response when cookware is placed on top or removed.
- ◆ In comparison to gas stoves, induction cooktops provide wide temperature range and accurately maintains both high boiling temperatures and lower simmer temperatures. Digital controls allow an easy setting of temperature as per need.
- ◆ Induction stoves do not emit any toxic gases from the heating element, and they keep the kitchen much cooler and as there's no open flames.

### **Note:**



- ◆ Homeowners can use any kind of iron pan or pots for cooking on induction. This also includes enamel or ceramic coated iron, stainless steel cooking pots, as well as blue steel.



Figure 20: Induction Cooktop

- ◆ They can use aluminum or copper only if the base of the utensil has an iron or steel coating (only iron & steel can work on induction).

- ◆ *Specification:* a generic multi burner induction stove top requires a dedicated 240V circuit from electrical panel and it draws up to 40 amps current. Portable 2 burner cooktops require 120V circuit & draws 15 amp current.

- ◆ *Price:* For a high end multi burner stove can cost up to \$4000 and a portable cooktop can cost up to \$1500.

- ◆ It is recommended to buy an induction stove with a sensor that doesn't allow the burner to be turned on unless it senses a pan and it should automatically turns off in a few seconds once the cookware is removed.

- ◆ Available brands in the market include Samsung, GE, Frigidaire, KitchenAid.

### 3.4 Heat Pump Dryer

A heat pump dryer works as a closed loop system by heating the air using it to remove moisture from the clothes and then reusing it once the moisture is removed. Rather than releasing warm, humid air through a dryer vent to the exterior of the home (like a conventional dryer), the heat pump sends it through an evaporator to remove the moisture without losing too much heat. It uses less electricity to generate heat as it has a refrigerant as part of this process just like a regular heat pump. They are highly energy efficient and environment friendly.

#### Benefits of Heat Pump Dryer:

- Innovative heat pump technology which uses air heat for drying clothes, greatly reducing energy consumption.
- They have built-in sensors that measure the

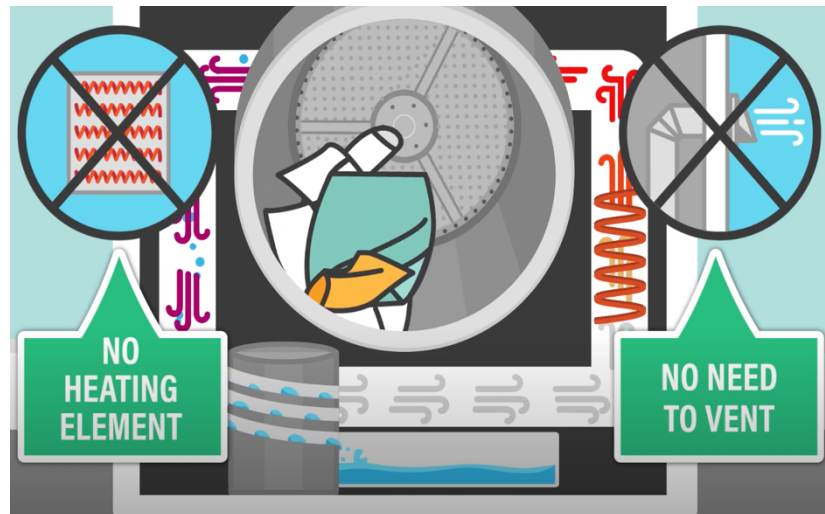

Figure 21: Typical Heat Pump Dryer.

- temperature and remaining moisture constantly, thus protecting laundry from excessively high temperatures and over drying.
- They are comparatively easy to install since they don't require ventilation.

- It reduces energy usage by at least 28% compared to standard dryers, thus reducing the utility bill in a long run.
- They have a quick dry option which can dry almost 8Kg of clothes in 41 minutes.

**Note:**

- A heat pump dryer's evaporator removes moisture from the air during the drying process, resulting in water that needs to be drained. Easy solution includes manually draining the water, using a drain hose to discard the water automatically in a nearby sink or drainpipe. Some manufactures install a device that allows the dryer to use the clothes washer drain to remove the water.
- They also come in compact models which can be installed in any tight space with access to electricity & water drainage.
- Specification: They require a dedicated 240V circuit from the electrical panel and draws almost 30 amps current.
- Price: High end, large capacity models can cost up to \$3000. (Get a final quote from a local appliance dealer). Available brands in market include Bosch, GE, Whirlpool & Samsung.
- To make sure the product is energy efficient, always consider ENERGY STAR-certified products.

## 3.5.0 Smart Home Devices

### 3.5.1 Smart Thermostat

Since heating and cooling comprise about half of the utility bill, its recommended to install some kind of smart technology that



Figure 22: Smart Thermostat

will help the homeowner save money on their utility bill. One such great product is *Smart Thermostat*. A Smart Thermostat connects heating and cooling systems to a smartphone, smart speaker or a computer. It helps user to schedule turning on/off of the system, change the temperature remotely and it can also remind about scheduled maintenance of the system. This unique capability makes operation more convenient, offering greater control of heating and cooling and overall energy savings. It comprises of 3 basic components: first component plugs directly into the HVAC system. This part communicates directly with second component which is the thermostat control itself. The third component is the software application that can be downloaded on any smartphone or tablet and lets you adjust home temperatures from any location (must have wireless connection).

## **Benefits of smart thermostat:**

- ◆ Wi-fi enabled smart thermostats are great at efficiently running home's heating and cooling system. From most thermostat models available in the market, homeowners can program the thermostat with ease. They can turn on & off the system at certain times which automatically reduces operation when on vacation, or program different temperatures based on season of time of the day and lot more stuff. Overall it helps to lower utility bill in long run.
- ◆ Some smart thermostats can learn schedules and preferences based on past usage information. In the matter of days, it can learn at times when the homeowner increased or decreased the temperature and it automatically sets the optimal temperature for comfort.
- ◆ Unlike manual thermostats that only control heating & cooling system, some smart thermostats are designed to control all of the home indoor air quality systems like air purification or a dehumidifier system as well.
- ◆ Many wi-fi enabled thermostats push notification/alerts directly to user smartphone/tablet. When the system has encountered an electrical issue or it's a maintenance time for the filter, the system generates an alert to remind that.
- ◆ Most smart thermostats allow users to track their energy usage. A user can build a home energy profile that tells them how their energy usage has changed over time and how likely it affects the energy cost in the future.

- ◆ Price: Typical costs around \$500. Currently available smart thermostats in the market includes Nest, Honeywell, Ecobee, Johnson controls etc.

### 3.5.2 Smart Home Energy Manager.

Home automation systems are increasingly popular as it increases the comfort, savings in energy and utility bill through smart energy management and enhanced home security. A home automation system is a computer-based control system that

is installed in order to integrate, monitor and control both electrical and mechanical devices within the home via a software application that can easily be accessed remotely. Each electronic device and appliance in a home has its own unique energy signature. Using advanced machine learning technology, the smart manager identifies each unique electrical signal, and uses that data to further learn

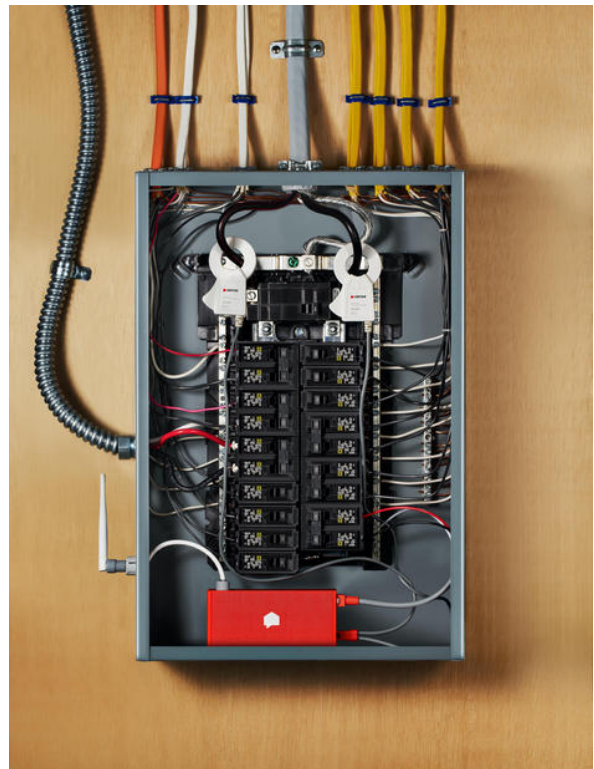

Figure 23: Typical Energy manager installation

and provide useful information about daily/weekly energy consumption and change in usage behavior to the homeowners. The energy manager continuously and smartly learns new patterns, signatures and behaviors and updates its database regularly to accelerate new device identification.

## Benefits of Smart Home Manager

- It gives 24/7 access to homeowners so that they can see what appliance is on/off and make smarter choices.
- Homeowners can create custom notifications, letting them know when to switch on/off a device or if any electrical equipment is left on for a longer period of time.
- It helps to set energy usage goals, estimate monthly energy bills and take proactive actions to cut down on energy wastage. In some advanced management

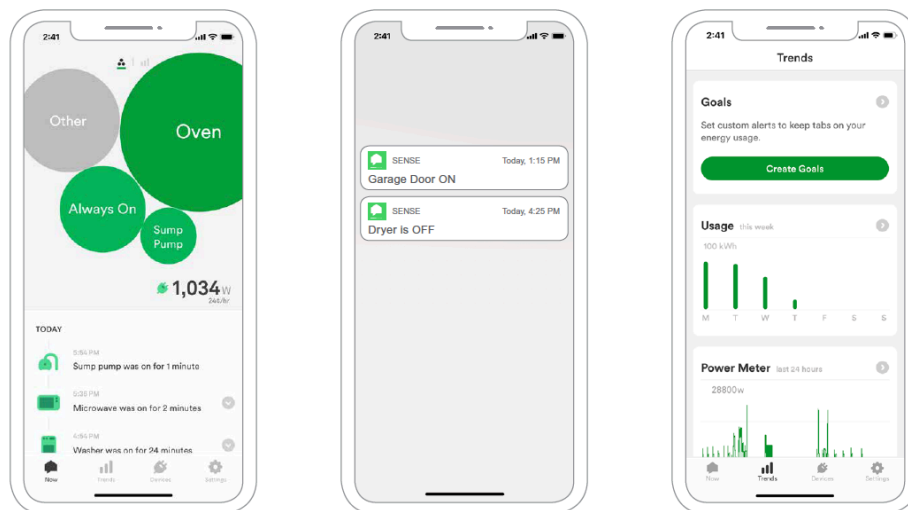

Figure 24: User interface dashboard (Source: Wiser smart energy manager)

systems, it can integrate solar energy generation and monitor return on investment if the house is equipped with solar panels.

- Available brands in the market includes: Sense, Wiser and other 3<sup>rd</sup> party start-up companies.

## 3.6 Electric Vehicles & Residential EV Charging

There are many reasons to make the next car purchase an electric car. Lower fuel costs, environmental stewardship and energy independence are all compelling reasons to go electric with your next car. This section talks about basics of EV, & Hybrid cars, their benefits and what is required for installing an EV charging station at home.

*All-electric vehicles or EVs* have an electric motor instead of an internal combustion engine. The vehicle uses a large traction battery pack to power the electric motor and must be plugged in a wall outlet at home or a charging station. Because it runs on electricity, the vehicle emits no exhaust from the tailpipe (almost zero greenhouse gas emissions when compared to burning fossil fuels like gasoline). Most electric vehicle models available in the market have a rated range between 200-250km on a full charge, while some high-end models can go up to 400+ km (note: range is affected by road conditions, weather conditions and driving habits). Car brands in market currently are Tesla, BMW i3, Nissan Leaf, Chevrolet Bolt EV, Smart EQ fortwo, Mitsubishi i-MiEV, Mini Cooper SE.

*Plug-in Hybrid electric vehicles* are powered by both gasoline and electricity. They have a rechargeable battery packs that provide 20-80 km of all-electric driving before a gasoline engine or generator turns on for longer trips. Because of the rechargeable battery in them, they are much cheaper to operate compared to



traditional gasoline/diesel cars (in most advanced newer model plugin hybrids). Car brands available in market currently are Toyota Prius Prime, Kia Optima PHEV, Hyundai IONIQ ELECTRIC Plus, Chrysler Pacifica Hybrid.

## **Benefits of Electric Car**

Since the car is fueled by electricity, it offers some great advantages that are not available in traditional cars.

- EVs are very responsive and have good torque as electric motors react to changes quickly.
- By choosing an electric vehicle, user can forget about paying for gas or regular visit of gas station (in case of plug-in hybrids). Not only electricity is cheaper than gasoline, it also has more stable price point (not affected by market ups and downs on oil price).
- All electric vehicles have fewer moving parts than a conventional car. Thus, they require less overall servicing and maintenance. Most car manufacturers offer 8 years of warranty on their EV batteries. EVs can help reduce the GHG emissions that contribute to climate change and smog, improve public health and reduce ecological damage. *(Direct emissions from burning gasoline are emitted through the tailpipe, through evaporation from the fuel system, and during the fueling process. Direct emissions include smog-forming pollutants (such as nitrogen oxides), other pollutants harmful to human health, and*

*greenhouse gases (GHGs), primarily carbon dioxide. All-electric vehicles produce zero direct emissions, which specifically helps improve air quality in urban areas)*

- The cost of charging depends on the type of electric vehicle and driving habits. For example, driving a small electric vehicle 13,000 km in a year would cost around \$300-\$350/year in electricity, or less than \$1/day. This annual electricity cost is less than a typical residential water heater. There's almost 80-90% reduction in cost when compared to traditional IC engine cars in Vancouver. (Source: Metro Vancouver Website)

## **Equipment to Charge at Home**

There are number of manufacturers who are now offering EV chargers in various models. Before buying a charger, homeowner should make sure that the EV charger is safety certified and only get it installed by a Red Seal Certified electrician or an authorized EV installation company. Once the homeowner has scheduled an appointment with an EV installer or Electrician, they will assess the electrical service i.e. the electrical panel and high load appliance, do the load calculation and finally propose a charging station which is best suited for their needs.

**Note:** If the homeowner is looking to install an EV charger at home, it is highly likely that they would requires a permit. It is recommended to the homeowners to check with the city office if they need permit and apply for the same.

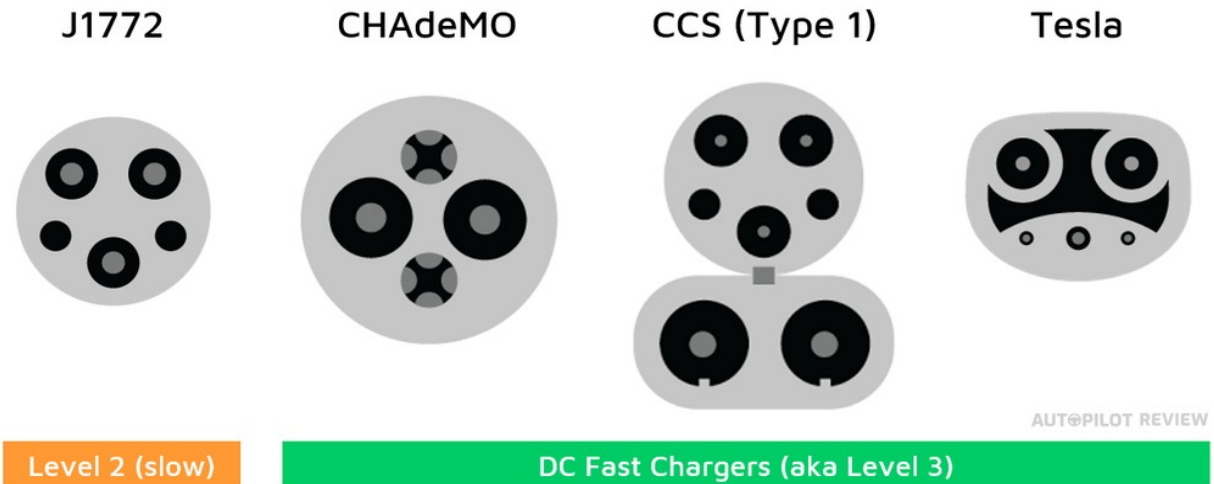

Figure 25: Typical Charging Connector (Source: Autopilot review, 2020)

### Various features to look for before buying:

*Connector:* Most EVs have the “J Plug (J1772)” which is used for home & level 2 charging. There are two other plugs available in the market which are “CCS” (for cars like BMWi, General Motors & Volkswagen), and the “CHAdeMO” by Mitsubishi & NISSAN. Tesla makes its own proprietary plug, but homeowners can use the above plugs with adapters.

*Single or Dual port:* Charging stations designed from multi-EV use in common areas have two plugs that can be used at the same time (*Dual port for commercial units*).

*Cord length:* Cords are available in a range of lengths, the most common being 5 meters and 7.6 meters. Shorter cables are easier to store but longer cables provide flexibility if the driver has to park the car further from the charging location.

*Indoor or Outdoor:* For indoor charging station regular charger works fine but if the charging station is outdoor, user need to make sure that the charger is weatherproof. Also, it is recommended to make sure the charger meets electrical code requirement & permit requirement from the city. Contact a local red seal certified electrician for more information.

*Portable or Permanent:* the available chargers in the market can be plug into an outlet or installed on a wall.

*Sub-meter(optional):* A homeowner may install a separate sub-meter to track the electricity usage for charging, without being connected to the building's electricity account. (note: - more info available from BC Hydro or FortisBC)

*Installation Cost:* Installation cost varies based on

- ◆ Number of circuits and chargers installed. More the chargers, more the cost.
- ◆ Distance between the charger and electrical room/garage.
- ◆ House age as older houses might need more electrical work to make things work.  
For example: cost will increase if there is a need to drill through concrete to run conduit or trench landscaping or asphalt.
- ◆ Electrical upgrades can increase installation costs significantly. Older homes might not have a capacity to add an EV charger so the homeowner will need to either do electrical panel upgrade or install a smart EV energy management system to make it work.

*Electrical System:* based on type of charger the homeowners needs there are 3 different kinds.

### **Level 1 Charger**

- Needs a 120V outlet and draws almost 15-20 amp current.
- Charges 8km per hour.
- Takes almost 12-20hrs to fully charge depending on whether full EV or Hybrid plug-in. (quicker for hybrid)
- Well suited for home installation.
- Installation cost can vary from \$300-\$2500 (charger is included with the car purchase).

### **Level 2 Charger**

- Uses a dedicated 240V connection from the electrical panel and can draw up to 30 to 80 amps (depends on the car model and requirement).
- Charges 30km per hour.
- Takes 6-12hrs to fully charge (.).
- Best suited for homes, businesses and common areas.
- Total cost can vary from \$2000-\$6000 (includes the charger and installation cost.)

### **Level 3 Charger (also known as a Fast Chargers)**

- Uses a dedicated 480V connection from the electrical panel and can draw up to 80 amps.
- Charges 100km per 30 mins or 80% charge at 50kW (varies by vehicle type).
- Takes 1- 4hrs to fully charge a battery EV & 15mins to 3hrs for a plug-in hybrid.
- Only used in businesses and commercial space.

Note: Most drivers in Vancouver typically drive ~22Km per day. So required charging time would be less for typical driving in the city.

# 4.0 Energy Efficient Homes & EnerGuide Audit

An energy-efficient home is comfortable, healthy, environmentally friendly and cost-efficient. A home energy audit, also known as EnerGuide Home Evaluation is the first step to improve the overall efficiency of the home. An audit will help a homeowner identify ways to improve the home’s overall comfort and efficiency, which will save homeowners money on utility bill in long run.

## Benefits of EnerGuide home evaluation.

### LEARN ABOUT YOUR HOME'S ENERGY rating

You will receive a rating of the home's energy consumption in gigajoules

### AIM TOWARDS zero

The lower the number on the new **EnerGuide** scale, the better the energy performance of your home

### UNDERSTAND HOW YOU USE energy

The label breaks down energy consumed by source

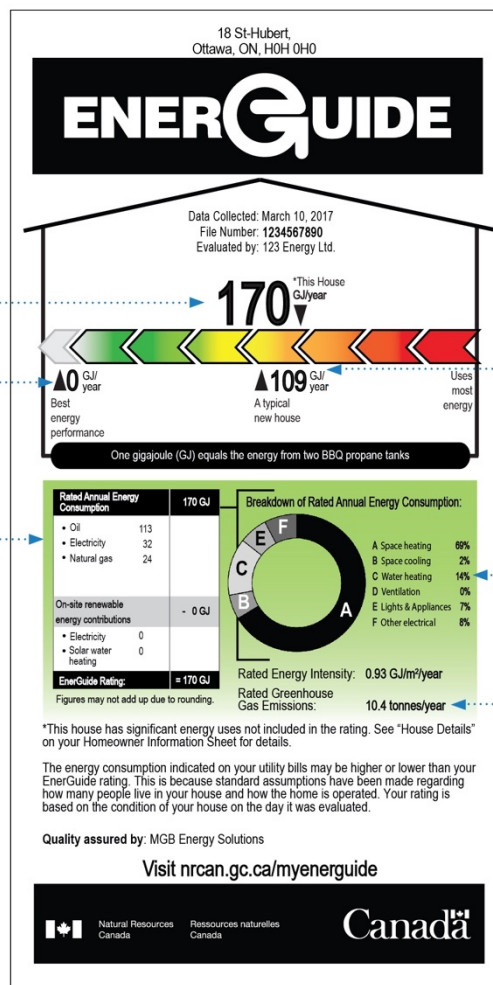

### COMPARE YOUR HOME'S performance

The label shows how your home's performance compares to a benchmark home

### FIND OUT WHERE MOST ENERGY IS consumed

The label shows proportion of energy consumed by heating, cooling, ventilation, etc.

### SEE YOUR IMPACT ON THE environment

The label shows your home's Greenhouse Gas Emissions

Figure 26: Typical EnerGuide Report

The EnerGuide report gives a thorough understanding of the home's overall efficiency. The report will show a detailed information about various home energy improvement opportunities.

- ◆ The personalized report will recommend upgrades to help eliminate drafts, reduce noise and provide consistent temperatures and cleaner air. It will enhance the overall environment of the home.
- ◆ The report will also show where to make improvements and which ones are the most important to work on to improve the home's energy performance. That will help the homeowner reduce their energy consumption and utility bill.
- ◆ All the necessary efficiency upgrades will help increase the value of the home. An EnerGuide efficiency label becomes a real selling point for prospective buyers.
- ◆ It will also help homeowners to claim for various incentives and rebate programs started by the state and local government which will help curb the expenses incurred during the upgrades.

**Note 1:** An Energuide Home Evaluation is performed only by a *Certified Energy Advisor* who will examine things such as home's air leakage, insulation, furnace and ductwork. Following the audit, the energy advisor will provide homeowner with a personalized report with recommendation for upgrades. It also includes home

efficiency rating which can be used to compare home comparison against post-upgrades rating. (*more information available on EnerGuide & BC Hydro website*)

### ***Energuide Rating***

- A 0 rating represents a house with major air leakage, no insulation and high fuel consumption.
- A 100 rating represents an airtight, well-insulated house where energy purchased is equal to energy generated through renewable sources.
- The higher the number, the more efficient the house.
- An energy-efficient, upgraded older home typically rates between 66 and 74.
- An energy-efficient new home rates between 81 and 85.

**Note 2:** Pre-upgrade evaluations typically range from \$400 to \$600 and may include additional fees. Post-upgrade evaluations typically cost between \$200 and \$300 and may include additional fees.

## **4.1 Making Small Changes that Add Up**

- A homeowner can save energy and money by making modest investments and minor changes around the home. Improvements can be done both inside and outside of the home.
- Upgrading insulation and air seal of the homes are some of the most cost-effective home improvements.



- Replacing traditional heating & cooling systems with air source heat pumps. It is energy-efficient and can supply both heating and cooling for the home. It is

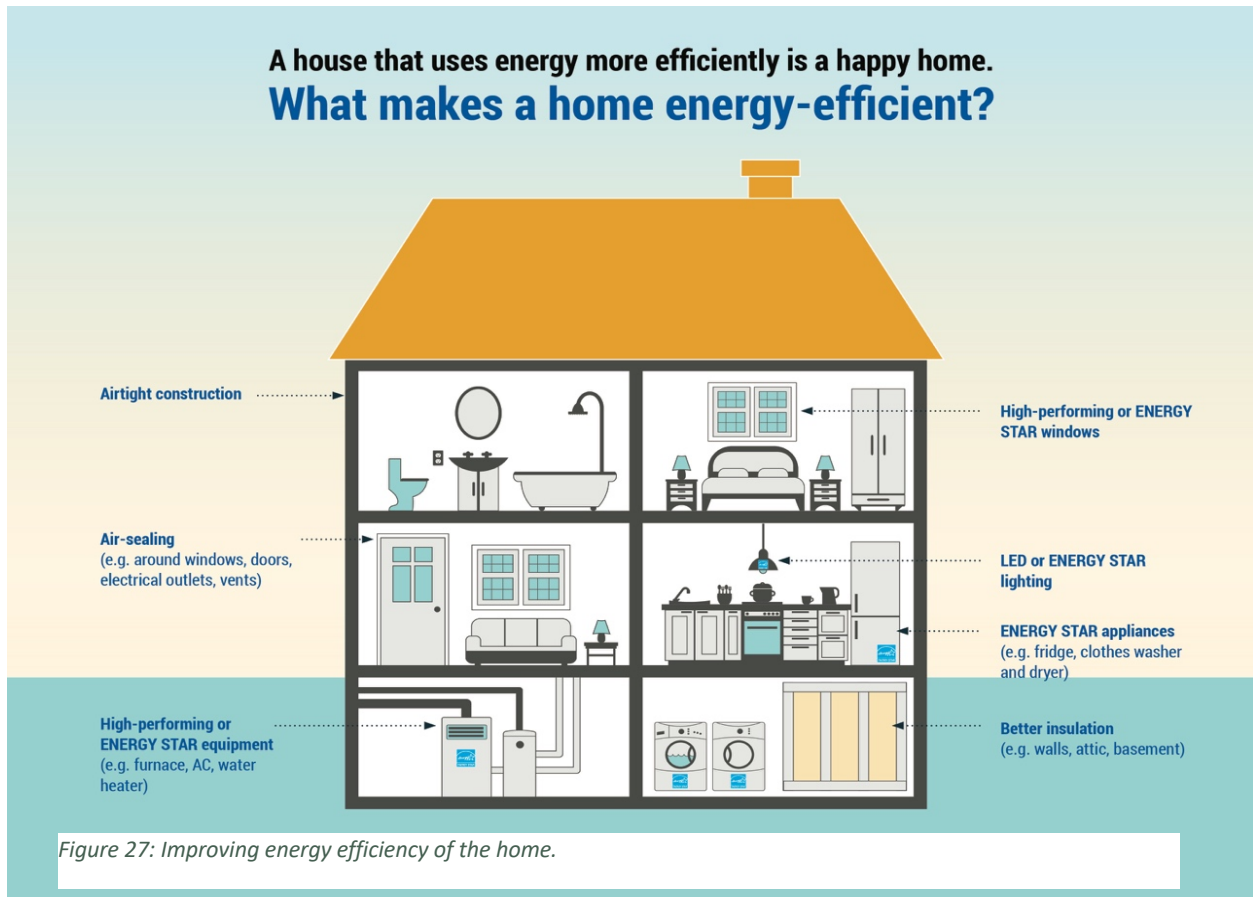

recommended to keep ASHP clear of bushes or debris that could restrict air flow.

- Install an ENERGY STAR certified smart-thermostat to take control of heating and cooling.
- Apply weatherstripping around older exterior doors to reduce air loss.
- Replace older appliances with new ENERGY STAR certified all electric appliances that will reduce energy consumption and save only utility bill.
- Install windows with triple glazing on the east and north facing side of the house to minimize heating or cooling waste.

- Replace older water heaters with Heat Pump water heaters.
- Seal all supply ductwork with aluminum foil duct tape, approved flexible plastic tape or water-based mastic to improve comfort.
- Making sure heating, cooling and ventilation ducts running through basements, crawl spaces or unheated attics are sealed and insulated.
- It is recommended to ensure heating, cooling and ventilation distribution system is balanced i.e. undersized ductwork, leaking ducts, inadequate or poorly placed return air grilles can mean discomfort and higher heating bills.

## 5.0 Incentive & Rebate Programs

Doing an electrical service upgrade or replacing natural gas-based heating/cooling system & water heaters can be an expensive process for the homeowners. So, the BC government & City of Vancouver started “***Home Renovation Rebate Program & CleanBC Home Efficiency Rebates***” in order to encourage BC resident homeowners to move towards a cleaner, healthier and more environment friendly living. This rebate program also helps homeowners to curb some of the expenses made in those upgrades. At time of writing, there are available rebates for windows, insulation, heat pumps, electrical panel upgrades and EnerGuide assessments. Please visit [www.BetterHomesBC.ca](http://www.BetterHomesBC.ca) for details on rebate and eligibility requirements.

**Effective date: For invoices dated on or after April 1, 2020**

**Note:** *All the below rules, requirements and regulations has been taken from CleanBC website*

- 1) Home must be a year-round primary residence and one of the following types of residential buildings:
  - a) single family home (detached dwelling).
  - b) secondary suite in a single-family home (detached dwelling); the home and secondary suite must be individually metered.
  - c) mobile home that is permanently fixed, sits on a foundation and is structurally complete with installed and connected plumbing, heating, electrical, water and sewer services; towing apparatus and axle must be removed.
  - d) side-by-side or stacked duplex, each unit must have its own natural gas and/or electricity meter. Utility accounts must be in the name of the resident and/or

- homeowner; utility accounts in the name of a strata corporation are not eligible.
- e) side-by-side row home or townhomes, each unit must have its own natural gas and/or electricity meter. Utility accounts must be in the name of the resident and/or homeowner; utility accounts in the name of a strata corporation are not eligible.
- 2) The following types of homes are not eligible:
- a) multi-unit residential buildings such as condominiums, high-rises and apartment buildings;
  - b) stacked townhomes;
  - c) garages, workshops, and outbuildings; and
  - a) new homes, including homes that are defined as “substantially reconstructed,” by the Homeowner Protection Act (as per Regulatory Bulletin: Substantially Reconstructed Homes and the Homeowner Protection Act (No. 6)) or additions to existing homes. An existing space, such as a garage or solarium, converted into a living space is considered a new addition.
- 3) The home must be connected to a residential account with one of the following utilities:
- a) FortisBC natural gas
  - b) FortisBC Inc.
  - c) BC Hydro
  - d) City of New Westminster
  - e) City of Penticton
  - f) City of Grand Forks
  - g) Nelson Hydro
  - h) District of Summerland
  - i) Pacific Northern Gas
- 4) The home must be primarily heated by one of the following (a primary heating system must have the capacity to heat a minimum of 50% of the home for the entire heating season to 210C):
- a) natural gas, propane or oil (a fireplace is not considered a primary heating system).
  - b) electricity (hard-wired electric heating systems such as electric baseboards, radiant ceilings, radiant floors, forced-air, or heat pump).
  - c) homes primarily heated by wood or other solid fuels are only eligible for the following rebates:
    - i. natural gas water heater or heat pump water heater
    - ii. pre-upgrade EnerGuide Home Evaluation
    - iii. post-upgrade EnerGuide Home Evaluation

- a) homes primarily heated by natural gas supplied by Pacific Northern Gas Ltd. are only eligible for the following rebates:
  - i) insulation
  - ii) windows and doors
  - iii) air source heat pump (convert from fossil fuel)
  - iv) air source heat pump with fossil fuel back up (dual fuel system)
  - v) heat pump water heater (convert from fossil fuel or electric)
  - vi) air-to-water heat pump (convert from fossil fuel)
  - vii) pre-upgrade EnerGuide Home Evaluation
  - viii) post-upgrade EnerGuide Home Evaluation
  - ix) Two Upgrade Bonus
  - x) Home Energy Improvement Bonus
- 5) Homes must have 12 months of continuous utility billing for the period immediately prior to the installation of the Upgrade(s).
- 6) All upgrades must be installed by a contractor with a GST number and a valid B.C. business license for the trade related to the upgrade being installed (e.g. Contractor—Electrical, Contractor—Heating, Inter-municipal trades and construction business license).
- 7) Rebates cannot exceed the cost on the invoice and the paid cost of the upgrade.
- 8) Rebates can only be claimed once.

**Note: Additional Terms and Conditions apply.**

**Visit: [bchydro.com/homerebates](http://bchydro.com/homerebates), [fortisbc.com/homerebates](http://fortisbc.com/homerebates) or [betterhomesbc.ca](http://betterhomesbc.ca) for full details. LOT MORE OFFERS AND PROGRAMS AVAILABLE ON THE WEBSITE. Subject to change.**

## **5.1 Electrical Service Upgrade Rebate**

Rebate requirements:

- 1) Only homes that convert from a fossil fuel (oil, propane or natural gas) primary space and/or water heating system to a heat pumps are eligible. A primary heating system must have the capacity to heat a minimum of 50% of the home for the entire heating season to 210C.
- 2) The service upgrade (new wire) is for 100, 200- or 400-amp service to an existing home.
- 3) Eligible expenses include:
  - i) utility connection fees
  - ii) electrical panel or sub-panel upgrade
  - iii) service mast alterations or replacement
  - iv) conduit replacement, meter base alterations or replacements

- v) weather head alteration or replacement
  - vi) labor.
- 4) All upgrades must be installed by a contractor with a GST number and a valid B.C. business license for the trade related to the upgrade being installed (e.g. Contractor—Electrical, Contractor—Heating, Inter-municipal trades and construction business license).

**REBATE VALUE:** \$500

**REBATE MAXIMUM:** Maximum of One Electrical Service Upgrade Rebate Per Home.

**BONUS ELIGIBILITY:** None.

Supporting documentation:

- 1) Paid utility bill or invoice for the electrical service upgrade (100, 200, or 400-amp service).
- 2) Paid contractor invoice.

Deadlines:

The rebate application and supporting documentation must be submitted within six (6) months of the invoice date.

## 5.2 Energuide Home Evaluations Rebate

Rebate requirements:

- a) EnerGuide home evaluations must be performed by a Program Qualified Energy Advisor listed at [betterhomesbc.ca/ea](http://betterhomesbc.ca/ea).
- b) A pre-upgrade EnerGuide home evaluation must be completed before a post-upgrade EnerGuide home evaluation.

Pre-Upgrade Energuide Home Evaluation Rebate	\$200 (rebate)	Maximum of one pre-upgrade	Not bonus eligible.
Post-Upgrade Energuide Home Evaluation Rebate	\$100 (rebate)	Maximum of one post-upgrade	Not bonus eligible

Supporting documentation:

1. Paid invoice for pre-upgrade EnerGuide home evaluation and/or post-upgrade

EnerGuide home evaluation.

Deadlines:

1. The Pre-Upgrade EnerGuide Home Evaluation Rebate application and supporting documentation must be submitted within six (6) months of the date of the evaluation.
2. The post-upgrade EnerGuide home evaluation must be completed within 18 months of the pre-Upgrade EnerGuide Home evaluation. The rebate application and supporting documentation must be submitted within six (6) months of the date of the evaluation.

### **5.3 Home Energy Improvement Bonus**

Rebate requirements:

1. A pre-upgrade EnerGuide home evaluation and post-upgrade EnerGuide home evaluation must be completed according to the requirements of the EnerGuide Home Evaluations rebate requirements.
2. At least three bonus-eligible upgrades must be installed in the home and a post-upgrade EnerGuide home evaluation must be completed within 18 months of the pre-upgrade EnerGuide home evaluation.
3. Refer to the list of bonus-eligible rebates.

Home Energy Improvement Bonus	\$20 per percentage improvement in Energuide rating (GJ/year), up to \$2000	Maximum of one home energy improvement bonus per premises.
-------------------------------	---	--

Deadlines:

The bonus application must be submitted within six (6) months of the date of the post-upgrade EnerGuide home evaluation.

### **6.4 Electric Heat Pump Water Heater Rebate (Convert from Fossil Fuel)**

Rebate requirements:

- 1) The heat pump water heater must replace a fossil fuel (oil, propane or natural gas) water heating system and all fossil fuel water heating equipment (piping, appliances, fuel containers, vents and associated infrastructure) must be removed or decommissioned in accordance with all applicable laws.

- 2) The existing water heater being replaced must be the home’s primary water heater.
- 3) Eligible systems are listed as Tier 2 or higher on NEEA’s Advanced Water Heater Specification Qualified Products List for Heat Pump Water Heaters.
- 4) Emergency replacement of fossil fuel water heating systems with heat pump water heaters are eligible.
- 5) All upgrades must be installed by a contractor with a GST number and a valid B.C. business license for the trade related to the upgrade being installed (e.g. Contractor—Electrical, Contractor—Heating, Inter-municipal trades and construction business license).

Heat Pump Water Heater	\$1000 (rebate)	Max one primary water heating system rebate per home	Qualifies as one bonus eligible rebate.
------------------------	-----------------	--	---

Supporting documentation:

- 1) Paid invoice (see sample invoice for requirements).
- 2) Proof of gas water heater removal. One of the following documents will be accepted:
  - a. local government permit or inspection report, which must include:
    - i. date of inspection
    - ii. address where inspection took place
  - b. invoice from the removal company or heat pump water heater installation company, which must include:
    - i. description of work completed (e.g. the gas water heater was removed according to applicable regulations and local government bylaws)
    - ii. date of removal

Deadlines:

The rebate application and supporting documentation must be submitted within six (6) months of the invoice date.

## 5.4 Air Source Heat Pump Rebate (Convert from Fossil Fuel)

Rebate requirements:

- a) The home must be primarily heated by fossil fuel (oil, propane or natural gas). A primary heating system must have the capacity to heat a minimum of 50% of the home for the entire heating season to 210C. A fireplace is not considered a primary heating system.



- b) The new heat pump must:
- i) be sized to function as the primary heating system for the home.
  - ii) serve a main living area (e.g. family room, living room or open-concept kitchen-living room).
  - iii) replace the existing fossil fuel heating system and all fossil fuel heating equipment (piping, appliances, fuel containers, vents and associated infrastructure) must be removed or decommissioned in accordance with all applicable laws.
  - iv) have an AHRI certified reference number that references all components of the heat pump.
  - v) be listed as a qualifying system on the Qualified Heat Pump Product List.
- c) Emergency replacement of fossil fuel space heating systems are eligible.
- d) Homes in Non-Integrated Areas of the electricity grid must contact [betterhomesbc@gov.bc.ca](mailto:betterhomesbc@gov.bc.ca) for pre-approval prior to installation.
- e) Products with a maximum static pressure of less than 0.6” Water Column (WC) are considered mini-split or multisplit systems.
- f) All upgrades must be installed by a contractor with a GST number and a valid B.C. business license for the trade related to the upgrade being installed (e.g. Contractor—Electrical, Contractor—Heating, Inter-municipal trades and construction business license).

Upgrade	Efficiency Requirement
Variable speed mini-split	1. SEER $\geq$ 16; HSPF (Region IV) $\geq$ 9.30 2. Variable speed compressor
Variable speed multi-split	1. SEER $\geq$ 16; HSPF (Region IV) $\geq$ 9.30 2. Variable speed compressor
Central system (Tier 1)	1. SEER $\geq$ 15; HSPF (Region IV) $\geq$ 8.50 2. Variable speed compressor not required
Variable speed central system (Tier 2)	1. SEER $\geq$ 16; HSPF (Region IV) $\geq$ 9.30 2. Variable speed compressor

Upgrade	Rebate	Rebate Max	Bonus eligibility
Variable speed mini-split	\$3,000	Maximum one primary space heating system	Qualifies as one bonus eligible rebate
Variable speed multi-split	\$3,000	Maximum one primary space heating system	Qualifies as one bonus eligible rebate
Central system (Tier 1)	\$1,200	Maximum one primary space heating system	Qualifies as one bonus eligible rebate

Variable speed central system (Tier 2)	\$3,000	Maximum one primary space heating system	Qualifies as one bonus eligible rebate
--	---------	--	--

Supporting documentation:

- 1) Paid invoice.
- 2) Proof of fossil fuel (oil, propane or natural gas) system removal or decommissioning. One of the following documents will be accepted:
  - a) local government permit or inspection report, which must include:
    - i) date of inspection
    - ii) address where inspection took place
  - b) invoice from the removal or decommissioning company or heat pump installation company, which must include:
    - i) description of the work completed (e.g. the oil system, including oil tank, was removed according to applicable regulations and local government bylaws)
    - ii) date of removal or decommissioning

Deadlines:

1. The rebate application and supporting documentation must be submitted within six (6) months of the invoice date.

## 5.5 CleanBC Go Electric EV Charger Rebate

Provincial rebates are available to support individuals, organizations, buildings, and companies. This program is funded by the Government of B.C.

To be eligible for rebates, condo/apartment and workplace applicants must submit their pre-approval application on or after September 26, 2019 and receive approval from BC Hydro before installing chargers.

### **Apartment and condo rebate amounts**

Apartment and condo rebates depend on when the building was constructed with respect to municipal bylaws requiring EV-ready parking stalls. Pre-approval from BC Hydro is required. Stations cannot be purchased and/or installed prior to receiving pre-approval.

- Constructed prior to municipal bylaws: Up to 50% of purchase and installation costs of eligible, new, Level 2 (208-volt or 240-volt) charging stations or energized outlets to a maximum of \$14,000 (up to a maximum of \$2,000 per station and up to a maximum of \$1,000 per energized outlet). Dual-port stations count as two.
- Constructed after municipal bylaws: Up to 50% of purchase and installation costs of eligible, new, Level 2 (208-volt or 240-volt) charging stations to a maximum of \$5,000 (no more than \$350 per station). Dual-port stations count as two.

*Note: More detailed info available at BC Hydro's rebate program. Subject to change.*

## **6.0 Future Research Prospects.**

The current report focuses more on single family dwelling only, but the information/upgrade methods can be applied to multi family, new construction and condominiums. There's a lot more areas where research can be made. Especially in heat pump and EV charging as these are the new emerging technologies and the government is encouraging more and more residents to move towards all electric houses or net zero homes and rely less on natural gas. Integration of solar panel and battery storage systems in the home can be another area of research. It can focus on whether it worth is investing in installing solar panels in homes in and around City of Vancouver and what challenges could be faced by the homeowners doing that. Also, what incentive programs can a homeowner can apply for to curb some expenses incurred. One final research area could be auditing a fully electric home in British Columbia in terms of quality of living, cost and compare it with a home which uses a traditional gas-based system.

## 7.0 References

- BC Hydro, & CleanBC. (2019). EV charger rebate program for apartments and workplaces. EV Charger Rebate for B.C. Apartments, Workplaces | BC Hydro. <https://app.bchydro.com/electric-vehicles/incentives/apartment-workplace-charger-rebate.html>.
- Vancouver, M. Key Information. Metro Vancouver. <http://www.metrovancouver.org/services/air-quality/climate-action/transportation-programs/ev-strata-condo/key-info/Pages/default.aspx>.
- CleanBC. (2020, July 8). CleanBC Better Homes and Home Renovation Rebate Program. Better Homes BC. <https://betterhomesbc.ca/rebates/cleanbc-better-homes-and-home-renovation-rebate-programs/>.
- CAA National. CAA. <https://www.caa.ca/electric-vehicles/faq-electric-vehicles/>.
- <https://www.svcleanenergy.org/electric-home/>
- Southern California Edison. (2020). Rebates & Incentives. SCE.com. <https://www.sce.com/residential/rebates-savings/rebates>.
- Sense, S. E. N. S. E. T. E. C. H. N. O. L. O. G. Y. (2017, October 25). How Does Sense Detect My Devices? Sense Blog. <https://blog.sense.com/articles/how-does-sense-detect-my-devices/>.
- ENERGY STAR Heating & Cooling Guide. ENERGY STAR. [https://www.energystar.gov/products/heating\\_cooling/guide](https://www.energystar.gov/products/heating_cooling/guide).
- Canada, N. R. (2020, March 10). Government of Canada. Natural Resources Canada. <https://www.nrcan.gc.ca/energy-efficiency/energuide-canada/energuide-energy-efficiency-home-evaluations/20552>.

- BC Hydro. (2020). Charges & fees for connections. BC Hydro - Power smart.  
<https://app.bchydro.com/accounts-billing/electrical-connections/charges-fees.html>.
- Vancouver, C. of. (2019). *Climate Emergency Response*. City of Vancouver.  
<https://vancouver.ca/green-vancouver/climate-emergency-response.aspx>.
- DCC Energy Management System  
[https://dccelectric.com/wp-content/uploads/2020/05/DCC\\_Specification-Sheet\\_DCC-10\\_V10-vf.pdf](https://dccelectric.com/wp-content/uploads/2020/05/DCC_Specification-Sheet_DCC-10_V10-vf.pdf) [dccelectric.com]
- Dryer Buddy  
<https://www.bsaelectronics.com/collections/dryer-buddys>
- Miser Switch  
<https://www.acdandy.com/bulletins/2019/6/2/load-miser-energy-divider-controller>
- Shockingly Simple Electrical for Tiny Houses By Ryan Mitchell.  
[www.tinylife.com](http://www.tinylife.com)

# Appendix: Canadian Electrical Code 2018 (Single Family Dwelling)

## 8-106 Use of demand factors

- 1) In any case other than a service calculated in accordance with Rules 8-200 and 8-202, where the design of an installation is based on requirements in excess of those given in this Section, the service and feeder capacities shall be increased accordingly.
- 2) Where two or more loads are installed so that only one can be used at any one time, the one providing the greatest demand shall be used in determining the calculated demand.
- 3) Where it is known that electric space-heating and air-conditioning loads are installed and will not be used simultaneously, whichever is the greater load shall be used in calculating the demand.
- 4) Where a feeder supplies loads of a cyclic or similar nature such that the maximum connected load will not be supplied at the same time, the ampacity of the feeder conductors shall be permitted to be based on the maximum load that may be connected at any one time.
- 5) Where a feeder or service supplies motor or air-conditioning loads, a demand factor as determined by a qualified person shall be permitted to be applied to these loads, provided that a deviation has been allowed in accordance with Rule 2-030.
- 6) The ampacity of conductors of feeders or branch circuits shall be in accordance with the Section(s) dealing with the respective equipment being supplied.
- 7) Notwithstanding the requirements of this Section, the ampacity of the conductors of a feeder or branch circuit need not exceed the ampacity of the conductors of the service or of the feeder from which they are supplied.
- 8) Where additional loads are to be added to an existing service or feeder, the augmented load shall be permitted to be calculated by adding the sum of the additional loads, with demand factors as permitted by this Code, to the maximum demand load of the existing installation as measured over the most recent 12-month period, but the new calculated load shall be subject to Rule 8-104 5) and 6).
- 9) For loads other than those calculated in accordance with Rules 8-200 and 8-202, feeder and service load calculations shall be permitted to be based on demonstrated loads, provided that such calculations are performed by a qualified person, as determined by the regulatory authority having jurisdiction.
- 10) Where electric vehicle supply equipment loads are controlled by an electric vehicle energy management system, the demand load for the electric vehicle supply equipment shall be equal to the maximum load allowed by the electric vehicle energy management system.
- 11) For the purposes of Rules 8-200 1) a) vi), 8-202 3) d), 8-204 1) d), 8-206 1) d), 8-208 1) d), and 8-210 c), where an electric vehicle energy management system as described in Subrule 10) monitors the consumer's service and feeders and controls the electric vehicle supply equipment loads in accordance with Rule 8-500, the demand load for the electric vehicle supply equipment shall not be required to be considered in the determination of the calculated load.

## **8-200 Single dwellings (see Appendix B)**

**1).** The calculated load for the service or feeder supplying a single dwelling shall be based on the greater of Item a) or b):

a)

- i) a basic load of 5000 W for the first 90 m<sup>2</sup> of living area (see Rule 8-110); plus
- ii) an additional 1000 W for each 90 m<sup>2</sup> or portion thereof in excess of 90 m<sup>2</sup>; plus
- iii) any electric space-heating loads provided for with demand factors as permitted in Section 62 plus any air-conditioning loads with a demand factor of 100%, subject to Rule 8-106 3); plus

iv) any electric range load provided for as follows: 6000 W for a single range plus 40% of any amount by which the rating of the range exceeds 12 kW; plus

v) any electric tankless water heaters or electric water heaters for steamers, swimming pools, hot tubs, or spas with a demand factor of 100%; plus

vi) except as permitted by Rule 8-106 11), any electric vehicle supply equipment loads with a demand factor of 100%; plus

vii) any loads provided for that have a rating in excess of 1500 W, in addition to those outlined in Items i) to vi), at

A) 25% of the rating of each load, if an electric range has been provided for; or

B) 100% of the combined load up to 6000 W, plus 25% of the combined load that exceeds 6000 W, if an electric range has not been provided for; or

b)

- i) 24 000 W where the floor area, exclusive of the basement floor area, is 80 m<sup>2</sup> or more; or
- ii) 14 400 W where the floor area, exclusive of the basement floor area, is less than 80 m<sup>2</sup>.

**2).** The calculated load for the consumer's service or feeder conductors supplying two or more dwelling units of row housing shall be based on

a) the calculated load in the dwelling unit, as determined in accordance with Subrule 1), excluding any electric space-heating loads and any air-conditioning loads, with application of demand factors to the calculated loads as required by Rule 8-202 3) a) i) to v); plus

b) the requirements of Rule 8-202 3) b) to e).

**3).** Notwithstanding Rule 86-302, the total load calculated in accordance with either Subrule 1) or 2) shall not be considered to be a continuous load for application of Rule 8-104.

### **Basic load**

It is intended by this definition that only a typical lighting and receptacle load within an area bound by the outside dimensions of that area signifies "basic load". Such loads as outside lighting, specialty lighting (i.e., stage, show window lighting, etc.), electric space heating, or air-conditioning loads are not intended to be part of the basic load. Code users should be aware that the value of basic load for each particular building occupancy is different and is dependent on the type of occupancy from Table 14 and on load calculation requirements for residential occupancies.



**Demonstrated load**

The intent of this definition is to allow comparison of loads that are used in a similar fashion based on the type of fuel source for heating and cooling, type of occupancy, type of occupancy load, and type of operational requirements. It is intended by this definition that comparison may need to be made between facilities in the same geographic area and also in similar climatic conditions. With respect to determining demonstrated load and recognition of qualified persons, Code users should be aware that it may be advisable to consult with the regulatory authority having jurisdiction.